

# Metropolitan Wastewater MANAGEMENT COMMISSION



*partners in wastewater management*

## ADDENDUM 02 PRIMARY CLARIFIERS AND FINAL TREATMENT CONCRETE REPAIR PROJECT NO. P80118

Date of Issue: May 14, 2026

Addendum Number 02 to the Bid Documents for MWMC Project P80118 is a part of the Contract Documents, and as such supersedes anything within the Contract Documents with which it may conflict.

Acknowledge receipt of this Addendum in the space provided in Section 00 41 00 BID FORM. Failure to do so may subject the Bidder to disqualification.

---

### **ADDITIONS, CHANGES, AND CLARIFICATIONS TO BID DOCUMENTS**

1. The following specification sections are revised as indicated. The attached specification sections replace the prior sections in their entirety:
  - a. 00 41 00 Bid Form – Revision made to clarify unit price estimated total
  - b. 00 43 93 Bid Submittal Checklist – Deleted requirements already completed during the prequalification process
  - c. 01 31 13 Project Coordination – Revision made regarding demo/reinstallation work at the primary clarifiers weirs and scum baffles
  - d. 01 50 00 Temporary Facilities and Controls – Revision made regarding temporary power for Contractor’s onsite job trailer and Contractor’s use of water available onsite
  - e. 03 01 32 Repair of Vertical and Overhead Concrete Surfaces – Revisions made regarding disposal of concrete facility wash water and water/debris from construction activities
  
2. Changes to process mechanical drawings. See attached, revised drawing sheets

3. The deadline for issuance of addenda is Monday, May 18, 2026 by 1:30 PM.
4. The questions and clarification requests below were generated from the pre-bid site visit, each followed by the answer provided, or a reference to where the answer can be found:
  - a. Can component panels of the primary clarifier circular flat aluminum covers removed for access to the Work be stored on other areas of the covers where the panels remain in place?

The Contractor may store clarifier cover panels removed for access on intact areas of the circular flat aluminum covers described herein only to the extent that the structural load capacities of the undisturbed areas remains intact and are not exceeded. Owner will provide drawings and specifications for the circular flat aluminum covers via links on the [MWMC Invitation to Bid webpage](#) where other project bidding information is found, but the Contractor must verify all dimensions and conditions in the field prior to disassembly and determine to what extent storage is possible without exceeding structural load capacities of the circular flat aluminum covers where storage takes place. In no case is storage allowed to exceed the capacities provided in Specification Section 05601(1.01)(D) Circular Flat Aluminum Covers from the Odorous Air Treatment Expansion Project, dated February 2009. Contractor must store cover panels removed for access in onsite laydown/staging areas provided by Owner to avoid overloading of intact areas of the clarifier covers. Fiberglass weir and scum baffle components removed for access to the Work may be stored within the main clarifier tank.

- b. How will the Contractor dispose of water used in final cleaning of each concrete facility?

Water used for final cleaning of each concrete facility, assuming only water is used with no added chemicals of any kind, can simply be washed down the existing facility drain. Water used for hydro-demolition and for preparation of repair areas, finishing, and curing may be disposed of onsite in accordance with Specification Section 03 01 32 Repair of Vertical and Overhead Concrete Surfaces.

- c. For costing purposes, what is the pipe sizing for the temporary bypass piping shown on Sheet 051-D-2001?

Contractor is responsible for sizing the temporary diversion piping in accordance with Specification Section 01 50 10 Bypass Pumping.

- d. Is a new tank penetration pipe spool needed at clarifier 1? Does the existing 3” supply need to change to feed the new pipe in the launder and the existing overhead pipe?

See revised process mechanical sheets and notes included with this addendum

- e. Will the Contractor need to provide new valves and full pipe replacement of the existing hose stations at clarifiers 1 and 3, or just connect new distribution piping where risers already exist above the aluminum cover?

See revised process mechanical sheets and notes included with this addendum

- f. What is the depth and distribution of chloride penetration in the contact basins?

Lab results of the core samples taken will be posted on the [MWMC Invitation to Bid webpage](#) where other project bidding information is found, but this is for information purposes only and must not to be used for bidding. Assumed depths for bidding purposes have been provided in the Bid Documents

- g. Will water for hydro-demolition be available onsite?

~~No.~~ See Specification Section 01 50 00, Subsection 3.01

- h. Would the Owner/Engineer like to have bond capacity testing performed on prepared substrate prior to placement of repair material?

Contractor may elect to perform a test of the existing substrate prior to repair material application, but a test is not required. Testing of the final system is still required as specified

- i. For repair system A (shotcrete mortar placement) would it be allowable to utilize wet mix process if the testing properties meet the project requirements?

Wet mix would be allowed provided the material meets all the minimum property requirements.

- j. In repair system B (low pressure spray) confirm whether manufacturer's requirements would supersede specifications. Most sprayable mortar systems do not utilize a bonding agent as the agent can be displaced during application thereby impeding the bond. Could this be validated in the mock-up phase?

Where manufacturer's requirements exceed those specified, the more stringent requirement will apply. For use of bonding agents, as noted in specification section 03 01 32 Repair of Vertical and Overhead Concrete Surfaces subsection 2.06.B, bonding agents are not required, however if bonding agent is used in the test repair and the test repair is approved for production, bonding agents must be used in production.

- k. Is there a specified joint sealant type and grade for this project to be utilized in expansion joints?

See revised Specification Section 03 01 32 Repair of Vertical and Overhead Concrete Surfaces included with this addendum

1. Are the swallows nesting at the Final Treatment CCBs protected, and how will they be handled?

The swallows are protected at both the state and federal levels, and are not allowed to be disturbed while nesting. Owner will remove swallow nests and/or prevent bird access during the off-season so that the area will be accessible for the Work in accordance with the Bid Documents.

5. See attached screenshot markups for crane access and laydown/staging area site locations

Project Manager on behalf of the Metropolitan Wastewater Management Commission

MWMC PRIMARY CLARIFIER AND  
FINAL TREATMENT CONCRETE REPAIR

**SECTION 00 41 00**  
**BID FORM**

**CONTRACT NUMBER [Project P80118]**

1.0 BID RECIPIENT

1.1 This Bid is submitted to:

Metropolitan Wastewater Management Commission  
Springfield City Hall  
225 Fifth Street, Suite 101  
Springfield, Oregon 97477

1.2 The undersigned, having full knowledge of the quality of the material and labor to be performed, hereby proposes to perform all labor and furnish all materials necessary for the Primary Clarifier and Final Treatment Structural Repair Contract P80118, for the prices as stated herein.

1.3 The undersigned as Bidder, declares that Bidder has received and examined the Contract Documents entitled Primary Clarifier and Final Treatment Structural Repair (Contract P80118), and will contract with the Metropolitan Wastewater Management Commission ("Owner") to do everything required for the fulfillment of the Contract for the construction at the prices and on the terms and conditions herein contained.

Bidder: \_\_\_\_\_

Date: \_\_\_\_\_

Person representing the bidder:

Name: \_\_\_\_\_

Address: \_\_\_\_\_

Telephone: \_\_\_\_\_

E-mail: \_\_\_\_\_

2.0 BIDDER'S ACKNOWLEDGEMENTS

Bidder accepts all of the terms and conditions of the Instructions to Bidders, including without limitation those dealing with the disposition of Bid security. This Bid will

## MWMC PRIMARY CLARIFIER AND FINAL TREATMENT CONCRETE REPAIR

remain subject to acceptance for 90 days after the Bid opening, or for such longer period of time that Bidder may agree to in writing upon request of Owner.

### 3.0 BIDDER'S DECLARATION AND REPRESENTATIONS

In submitting this Bid, Bidder represents that:

3.1 The undersigned Bidder declares that the only persons or parties interested in the Bid are those named herein, that this Bid is, in all respects, fair and without fraud, that it is made without collusion with any official of the Owner, and that the Bid is made without any connection or collusion with any person submitting another Bid on the Contract.

3.2 The Bidder further declares that they have carefully examined the Contract Documents entitled "Contract Documents for the construction of Primary Clarifier and Final Treatment Structural Repair Contract P80118 and that this Bid is made according to the provisions and under the terms of the Contract Documents, which documents are hereby made a part of this Bid.

3.3 Bidder has visited the site and become familiar with and is satisfied as to the general, local, and site conditions that may affect cost, progress, and performance of the Work.

3.4 Bidder has carefully studied all: i) reports of explorations and tests of subsurface conditions at or contiguous to the site and all drawings of physical conditions in or relating to existing surface or subsurface structures at or contiguous to the site (except underground facilities) that have been identified in specification Section 01 31 13, Project Coordination.

3.5 Bidder is familiar with and is satisfied as to all federal, state and local laws and regulations that may affect cost, progress, and performance of the Work.

3.6 Bidder does not consider that any further examinations, investigations, explorations, tests, studies, or data are necessary for the determination of this Bid for performance of the Work at the price(s) Bid and within the times and in accordance with the other terms and conditions of the Bid Documents.

3.7 Bidder has given Project Manager written notice of all conflicts, errors, ambiguities, or discrepancies that Bidder has discovered in the Bid Documents, and the written resolution thereof by Project Manager is acceptable to Bidder.

MWMC PRIMARY CLARIFIER AND  
FINAL TREATMENT CONCRETE REPAIR

3.8 The Bid Documents are generally sufficient to indicate and convey understanding of all terms and conditions for the performance of the Work for which this Bid is submitted.

4.0 FURTHER REPRESENTATIONS

Bidder further represents that:

4.1 This Bid is genuine and not made in the interest of or on behalf of any undisclosed individual or entity and is not submitted in conformity with any agreement or rules of any group, association, organization or corporation;

4.2 Bidder has not directly or indirectly induced or solicited any other Bidder to submit a false or sham Bid;

4.3 Bidder has not solicited or induced any individual or entity to refrain from bidding; and

4.4 Bidder has not sought by collusion to obtain for itself any advantage over any other Bidder or over Owner.

4.5 All required sales and use taxes are included in the stated Bid prices for the Work unless provision is made herein for the Bidder to separately itemize the estimated amount of sales tax.

4.6 Bidder agrees to be bound by and will comply with the provisions of ORS 279C.838; ORS 279C.840; or 40 U.S.C. 3141 to 3148 as applicable.

5.0 ADDENDA

Bidder has examined and carefully studied the Bid Documents, the other related data identified in the Bid Documents, and the following Addenda, receipt of which is hereby acknowledged.

<b>Addendum No.</b>	<b>Addendum Date</b>
_____	_____
_____	_____
_____	_____
_____	_____

(Bidder shall insert number of each Addendum received.)

MWMC PRIMARY CLARIFIER AND  
FINAL TREATMENT CONCRETE REPAIR

6.0 CONTRACT TIMES

The Bidder agrees that the Work, and any stages and/or milestones specified in specification Section 01 31 13, Project Coordination, will be substantially complete and will be completed and ready for final payment in accordance with the General Conditions on or before the dates or within the number of calendar days indicated in the Contract.

7.0 LIQUIDATED DAMAGES

Bidder accepts the provisions in the Contract as to Liquidated Damages.

8.0 CONTRACT EXECUTION AND BONDS

The Bidder agrees that if this Bid is accepted, it will, within 15 calendar days after notice of award is provided to Bidder, sign the Contract in the form annexed hereto, and will at that time deliver to the Owner the required bonds and certificates of insurance, and will, to the extent of this Bid, furnish all labor, machinery, tools, apparatus, and other means to do the Work and furnish all the materials necessary to complete the Work as specified in the Contract Documents.

9.0 LUMP SUM AND/OR UNIT PRICE WORK

9.1 The Bidder agrees to accept as full payment for the Work proposed herein the amounts computed under the provisions of the Contract Documents and based on the following lump sum or unit price amounts including installation of Owner-furnished equipment, it being expressly understood that the unit prices are independent of the exact quantities involved. The Bidder agrees that the lump sum prices and the unit prices represent a true measure of the labor and materials required to perform the Work, including all allowances for overhead and profit for each type and unit of Work specified in these Contract Documents. The Bidder shall provide prices for Work listed in numerical figures and words in the Schedule of Contract Prices.

SCHEDULE OF CONTRACT PRICES

9.2 The Work consists of all labor, materials, equipment and all other Work necessary for the completion of the following portions of the work described in the Bid Documents:

1. Work summarized in specification Section 01 11 00, Summary of Work.
7. Associated Sitework Improvements including Contractor Courtyard and Contractor Staging Areas.

9.2.1 LUMP SUM WORK: Bidder agrees to accept as full payment for the Lump Sum Work proposed within the Bid Documents, based upon the

MWMC PRIMARY CLARIFIER AND  
FINAL TREATMENT CONCRETE REPAIR

undersigned's own estimate of quantities and costs and including sales, consumer, use, and other taxes, except as provided below, and overhead and profit, the following lump sum of:

\_\_\_\_\_ Dollars  
(words)  
and \_\_\_\_\_ Cents     \$ \_\_\_\_\_  
(numerals)

9.2.2 UNIT PRICE WORK: The undersigned Bidder represents that, if awarded the Contract, the Total of all Extended Bid Unit prices as shown in the Unit Price Bid Schedule below will be supplied in accordance with Article 4.3 of specification Section 00 21 00, Instructions to Bidders. The estimated lump sum price of this work is:

\_\_\_\_\_ Dollars  
(words)  
and \_\_\_\_\_ Cents     \$ \_\_\_\_\_  
(numerals)

9.2.2.1 Unit prices have been computed in accordance with Article 4.3 of the Instructions to Bidders.

MWMC PRIMARY CLARIFIER AND  
FINAL TREATMENT CONCRETE REPAIR

9.2.2.2 Bidder acknowledges that estimated quantities are not guaranteed, and are solely for the purpose of comparison of Bids, and final payment for all unit price Bid items will be based on actual quantities, determined as provided in the Contract Documents.

UNIT PRICE BID SCHEDULE					
Item No.	Description	Estimated Quantity	Unit	Bid Unit Price	Extended Bid Unit Price
1	Primary Clarifier 1 and 3 Vertical Concrete Surface removal and repair – 5/8 to 1 inch removal depth and repair thickness	2,680	Square Feet	\$	\$
2	Primary Clarifier 1 and 3 Vertical Concrete Surface removal and repair – 1 1/8 to 1 1/2 inch removal depth and repair thickness	1,150	Square Feet	\$	\$
3	Primary Clarifier 1 and 3 Vertical Concrete Surface removal and repair – 1 5/8 to 2 inch removal depth and repair thickness	4,070	Square Feet	\$	\$
4	Primary Clarifier 1 and 3 Vertical Concrete Surface removal and repair – 2 1/8 to 2 1/2 inch removal depth and repair thickness	1,020	Square Feet	\$	\$
5	Chlorine Contact Basins 1-4 Vertical Concrete Surface removal and repair – 5/8 to 1 inch removal depth and repair thickness	44,440	Square Feet	\$	\$
6	Chlorine Contact Basins 1-4 Vertical Concrete Surface removal and repair – 1-1/8 to 1-1/2 inch removal depth and repair thickness	19,050	Square Feet	\$	\$
7	Chlorine Contact Basins 1-4 Vertical Concrete Surface removal and repair – 1 5/8 to 2 inch removal depth and repair thickness	17,190	Square Feet	\$	\$
8	Chlorine Contact Basins 1-4 Vertical Concrete Surface removal and repair – 2 1/8 to 2-1/2 inch removal depth and repair thickness	7,370	Square Feet	\$	\$
Total of All Extended Bid Unit Prices					\$

MWMC PRIMARY CLARIFIER AND  
FINAL TREATMENT CONCRETE REPAIR

9.2.3 BASE BID SUMMARY: The undersigned Bidder agrees to provide the Work as denoted in the summary table below for the lump sum price of:

\_\_\_\_\_ Dollars

(words)

and \_\_\_\_\_ Cents      \$ \_\_\_\_\_

(numerals)

**BASE BID SUMMARY**

Lump Sum Amount for supply of all Work included in the bid documents with the exception of items listed below in this Bid Summary (from 9.2.1):	
Total of all Extended Unit Bid Prices (from 9.2.2):	
<b>TOTAL BASE BID</b>	

9.2.4 BID ADDITIVE ALTERNATE ITEM 1: Bidder further agrees to accept as full payment for the Lump Sum Work proposed within these Contract Documents, for providing Chemical Resistant Coating in Chlorine Contact Basins as specified, in Section 01 23 00, Alternates, based upon the undersigned's own estimate of quantities and costs, for the following lump sum of:

\_\_\_\_\_ Dollars

(words)

and \_\_\_\_\_ Cents      \$ \_\_\_\_\_

(numerals)

9.2.5 BID ADDITIVE ALTERNATE ITEM 2: The Undersigned Bidder represents that, the Total of all Extended Bid Alternate Unit prices as shown in the Unit Price Bid Schedule below will be supplied in accordance with Article 4.3 of Section 00 21 00, Instruction to Bidders, for providing Polyurethane Injection for leak prevention on external wall of Primary Clarifiers as specified, in Section 01 23 00, Alternates, for the following lump sum of:

\_\_\_\_\_ Dollars

(words)

and \_\_\_\_\_ Cents      \$ \_\_\_\_\_

(numerals)

MWMC PRIMARY CLARIFIER AND  
FINAL TREATMENT CONCRETE REPAIR

9.2.5.1 Unit prices have been computed in accordance with Article 4.3 of the Instructions to Bidders.

9.2.5.2 Bidder acknowledges that estimated quantities are not guaranteed, and are solely for the purpose of comparison of Bids, and final payment for all unit price Bid items will be based on actual quantities, determined as provided in the Contract Documents.

UNIT PRICE BID SCHEDULE					
Item No.	Description	Estimated Quantity	Unit	Bid Unit Price	Extended Bid Unit Price
1	Mobilization of Polyurethane Injection Grouting Equipment, Material and Personnel for Dry weather season	4	EA	\$	\$
2	Polyurethane Injection Grouting	1000	Linear Feet	\$	\$
Total of All Extended Bid Unit Prices					\$

9.2.6 BASIS OF AWARD: The award of this Contract shall be made to the responsible bidder with the lowest Total Base Bid.

10.0 SUBCONTRACTORS

Bidder agrees to submit as part of its Bid, or within two (2) working hours after the effective Bid submittal time, the names of subcontractors as required in the **Instructions to Bidders** and by State law, whom Bidder, if awarded Contract, will name for performance of the categories of Work.

11.0 ALTERNATE ITEMS

11.1 After award of the Contract and if the Owner elects to delete or add any work covered by an Alternate Item, the Contractor will reduce or add to the Contract Price the amount set forth above for the Alternate Item designated by the Owner.

12.0 BIDDER

12.1 If the Bid is accepted, Bidder hereby agrees to contract with the Owner in the form of a Contract prepared by the Owner's Attorney to furnish the performance and payment bonds and the required evidence of the insurance within 15 calendar days after receiving written notice of the final award of the Contract.

MWMC PRIMARY CLARIFIER AND  
FINAL TREATMENT CONCRETE REPAIR

12.2 The Bidder further agrees, if its Bid is accepted and a Contract for performance of the Work is entered into with the Owner, to construct said project at the Lump Sum Amounts Bid and to so plan work and to prosecute it with such diligence that all of the Work shall be completed within the time stipulated in the Bid.

The name of the Bidder submitting this Bid is \_\_\_\_\_  
doing business at \_\_\_\_\_, \_\_\_\_\_, \_\_\_\_\_  
\_\_\_\_\_ Street \_\_\_\_\_ City \_\_\_\_\_  
State \_\_\_\_\_ Zip \_\_\_\_\_ which is the address to which all communications  
concerned with this Bid and with the Contract shall be sent.

Bidder's Federal Employer's Identification No. \_\_\_\_\_

RESIDENT/NONRESIDENT

The Bidder submitting this Bid \_\_\_\_\_ a resident bidder as defined in  
ORS 279A.120. (Bidder insert "is" or "is not," as appropriate.)

Oregon Construction Contractors Board Registration Number: \_\_\_\_\_

If Sole Proprietor or Partnership or Joint Venture

Names of partners (if co-partnership) or names of joint venturers (if a joint venture):

IN WITNESS hereto the undersigned has set (its) hand this \_\_\_\_\_ day of  
\_\_\_\_\_, 20\_\_\_\_.

\_\_\_\_\_  
Signature of Bidder

\_\_\_\_\_  
Name (typed)

\_\_\_\_\_  
Title

MWMC PRIMARY CLARIFIER AND  
FINAL TREATMENT CONCRETE REPAIR

If Corporation

IN WITNESS WHEREOF the undersigned corporation has caused this instrument to be executed and its seal affixed by its duly authorized officer this \_\_\_\_\_ day of \_\_\_\_\_, 20\_\_.

(Seal)

\_\_\_\_\_  
Name of Corporation

\_\_\_\_\_  
By

\_\_\_\_\_  
Title

Attest \_\_\_\_\_  
Secretary

**END OF SECTION**

**SECTION 00 43 93**  
**BID SUBMITTAL CHECKLIST**

**PART 1 GENERAL**

1.01 The following forms are to be executed by Bidder and submitted with Bid using the forms included in the Bid Documents.

NOTE: THE FIRST-TIER SUBCONTRACTOR DISCLOSURE AND NON-FIRST TIER SUBCONTRACTOR FORMS ARE REQUIRED TO BE SUBMITTED WITHIN TWO (2) HOURS OF THE DATE AND TIME WHEN BIDS ARE DUE

A. BID FORM – SPECIFICATION SECTION 00 41 00

The Bid prices must be shown in the spaces provided. Show prices in both words and numerical figures. Complete the statement of residency and acknowledgment of receipt of Addenda included in the Bid form.

B. BID SECURITY – SPECIFICATION SECTION 00 43 13

Each Bidder must submit Bid Security with his Bid, in the amount of ten percent (10%) of the base Bid, in accordance with ORS 279C.365.

C. PROPOSED EQUIPMENT AND SYSTEMS – SPECIFICATION SECTION 00 43 33

D. FIRST-TIER SUBCONTRACTOR DISCLOSURE – SPECIFICATION SECTION 00 43 37

Bidder must submit a Disclosure of any First Tier Subcontractors either with the Bid or within two (2) hours of the date and time when Bids are due.

E. NON-FIRST TIER SUBCONTRACTOR FORM – SPECIFICATION SECTION 00 43 38

Bidder must submit a list of proposed, non-first tier subcontractors either with the Bid or within two (2) hours of the date and time when Bids are due.

F. NON-COLLUSION AFFIDAVIT – SPECIFICATION SECTION 00 45 19

To be executed and submitted by Bidder.

G. BIDDER'S CERTIFICATION OF COMPLIANCE - SPECIFICATION SECTION 00 45 46

To be executed and submitted by Bidder.

MWMC PRIMARY CLARIFIER AND  
FINAL TREATMENT CONCRETE REPAIR

1.02 The following forms are to be executed and submitted by the successful Bidder within ten (10) days following Contract Award:

A. CONTRACT – SPECIFICATION SECTION 00 52 00

This Contract is to be executed by the successful Bidder and submitted in the required number of copies.

B. PERFORMANCE BOND – SPECIFICATION SECTION 00 61 14

To be executed by the successful Bidder and Bidder's surety company.

C. PAYMENT BOND – SPECIFICATION SECTION 00 61 15

To be executed by the successful Bidder and Bidder's surety company.

D. AFFIDAVIT – SPECIFICATION SECTION 00 45 47

To be executed by the authorized representative of successful Bidder's surety company.

E. WARRANTY FORM – SPECIFICATION SECTION 00 65 36

To be executed by the successful Bidder.

F. INSURANCE CERTIFICATES

Read, understand, and comply with insurance coverages required in Specification Section 00 72 00 General Conditions of the Contract.

**PART 2 PRODUCT (NOT USED)**

**PART 3 EXECUTION (NOT USED)**

**END OF SECTION**

**SECTION 01 31 13**  
**PROJECT COORDINATION**

**PART 1 GENERAL**

1.01 SUBMITTALS

- A. Work Sequence Plan: Submit within 30 days of Notice to Proceed.
- B. Photographs and other data of the preconstruction conditions shall be submitted to the Engineer for record purposes prior to, but not more than 3 weeks before, commencement of any construction activities.
- C. A complete set of all photographs and survey data of the post construction conditions shall be completed and submitted prior to final inspection by the Owner and Engineer.
- D. Shutdown Request Forms.

1.02 RELATED WORK AT SITE

- A. General:
  - 1. Other work that is either directly or indirectly related to scheduled performance of the Work under these Contract Documents, listed henceforth, is anticipated to be performed at Site by others.
  - 2. Coordinate the Work of these Contract Documents with work of others as specified in General Conditions.
  - 3. Include sequencing constraints and shutdown requests specified herein as a part of Progress Schedule.
- B. Other Concurrent Work:
  - 1. The Owner and Owner's contractors may be performing the following work during a period concurrent with the Work:
    - a. Aeration Systems Upgrades.
    - b. Admin Building Improvements.
    - c. Electrical Switchgear and transformer replacement.
    - d. Secondary clarifier mechanism recoating.

MWMC PRIMARY CLARIFIER AND  
FINAL TREATMENT CONCRETE REPAIR

- C. Contractor must comply with the use of VPM software for specified communications. Owner will pay all software and licensing costs for the collaboration software and provide Contractor two User Accounts to use. Owner will provide Contractor with one VPM training session for Contractor’s employees.

1.03 UTILITY NOTIFICATION AND COORDINATION

- A. Coordinate the Work with various utilities within Project limits. Notify applicable utilities prior to commencing Work, if damage occurs, or if conflicts or emergencies arise during Work.
  - 1. Electricity Company: Eugene Water and Electric Board.
    - a. Telephone: (541) 484-6016.
  - 2. Telephone Company: Qwest.
    - a. Telephone: (800) 603-6000.
  - 3. Water Department: Eugene Water and Electric Board.
    - a. Telephone: (541) 484-6016.
  - 4. Northwest Natural Gas.
    - a. Telephone: (541) 342-3661.
  - 5. Cable Company: Comcast.
    - a. Telephone: (888) 824-8264.
  - 6. Oregon Utility Notification Center.
    - a. Telephone: (800) 332-2344.

1.04 PROJECT MILESTONES

- A. Include the Milestones specified herein as a part of the Progress Schedule required under Section 01 32 16 Construction Progress Schedule.
- B. Project Milestones:
  - 1. Generally described in the Agreement Form. Following is a detailed description of each:

No.	Milestone	Substantial Completion (Calendar Days from Notice to Proceed)
1	Substantial Completion of Entire Contract	In accordance with Specification Section 00 52 00, Contract
2	Structural rehab and associated work for one chlorine contact basin and one covered primary clarifier	In accordance with Specification Section 00 52 00, Contract

**MWMC PRIMARY CLARIFIER AND  
FINAL TREATMENT CONCRETE REPAIR**

<b>No.</b>	<b>Milestone</b>	<b>Substantial Completion (Calendar Days from Notice to Proceed)</b>
3	Structural rehab and associated work for one chlorine contact basin and one covered primary clarifier	In accordance with Specification Section 00 52 00, Contract
4	Structural rehab and associated work for one chlorine contact basin and final treatment effluent channel	In accordance with Specification Section 00 52 00, Contract
5	Structural rehab and associated work for one chlorine contact basin.	In accordance with Specification Section 00 52 00, Contract
6	Final Completion of Entire Contract	In accordance with Specification Section 00 52 00, Contract

**1.05 WORK SEQUENCE AND CONSTRAINTS**

- A. For the purposes of this article, and Subsection 1.05(C) and 1.06 of this Specification Section, terms such as "... work ... must be completed" and "... completed and in operation," and "... in successful operation" are defined as meeting the terms of "Substantial Completion" and "Partial Substantial Completion" as defined in the General Conditions.
  
- B. Include the following work sequencing constraints in Progress Schedule:
  - 1. Concrete rehabilitation work is anticipated to occur over four consecutive dry-weather construction seasons.
  - 2. Contractor must coordinate all work with Owner and Engineer to accommodate activities described in the Scope of Work.
  - 3. Do not proceed with any work affecting facility operations without prior approval from Owner and Engineer regarding the need and duration of such work.
  - 4. Conduct a pre-activity coordination meeting with Owner and Engineer at least 2 weeks prior to mobilization and any shutdowns impacting operations.
  - 5. Perform work continuously during critical connections and changeovers to prevent operational interruptions.
  - 6. All primary clarifiers, chlorine contact basins and final treatment effluent channel must remain in service from the period of October 1 to May 31.

## MWMC PRIMARY CLARIFIER AND FINAL TREATMENT CONCRETE REPAIR

7. A maximum of one primary clarifiers may be out of service concurrently except as noted below.
8. Provide and size pumps to transfer primary clarifier effluent to and from the primary effluent conduit within an 8-hour period. Wash down and clean the chlorine contact basins and associated equipment as necessary to complete Work. Coordinate with Owner personnel on removal of chlorine contact basins from service and return to service.
9. Work requiring chlorine contact basins to be out of service must occur in dry season between June 1, and September 30 annually unless approved by Owner.
10. A maximum of one chlorine contact basin may be out of service concurrently except as noted below.
11. Provide and size pumps to transfer disinfected effluent to and from a chlorine contact basin to the final treatment effluent channel within an 8-hour period. Wash down and clean the chlorine contact basins and associated equipment as necessary to complete Work. Coordinate with Owner personnel on removal of chlorine contact basins from service and return to service.
12. Site civil work and plant utility work will be conducted throughout the overall construction schedule, integrated into the Project elements described above as specific areas of the Site are impacted.
13. More detailed constraints are given in Facility Operations below.

### C. Work Sequence:

1. To meet the overall objectives of the Project, certain tasks and task elements must be generally performed, completed, or substantially completed in the herein-specified sequences. However, two or more of the tasks or task elements may be pursued simultaneously when consistent with the requirements of this Specification section and specification Section 01 32 16, Construction Progress Schedule.
2. The specified sequences and tasks are not all-inclusive. They are intended to convey overall constraints and suggested construction sequences. Contractor must plan the Work, relocate facilities, reroute utilities, and provide for temporary connections and terminations as necessary in an appropriate sequence of operation to perform the Work, while minimizing interferences with and providing for continuous operation of the Owner's existing wastewater facilities.
3. Task headings and descriptions set forth below are descriptive only and are not intended to define the scope of Work included therein.
4. Major tasks and sequences have been identified for Owner's purposes. Tasks listed herein include all accompanying tasks such as, but not limited to, Site Work, interconnecting utilities associated infrastructure, and applicable temporary provisions necessary to sequence the Work.

MWMC PRIMARY CLARIFIER AND  
FINAL TREATMENT CONCRETE REPAIR

Temporary provisions must include pipeline endcaps, other utility terminations, and temporary utilities as necessary to allow operation of portions of the Work prior to completion of other portions of the Work, consistent with Contractor's sequence of operations, although such provisions are not shown.

5. All existing Owner facilities must remain in continuous operation except as specified herein.
6. Required Constraints and Suggested Task Sequencing:
  - a. Initial Sitework:
    - 1) Install erosion control measures.
    - 2) Install staging areas, separate Contractor entrance gates, and other Site security measures.
  - b. Chlorine Contact Basins Improvements:
    - 1) Coordinate with Owner to complete taking basin offline and lockout/tag out procedure.
    - 2) Transfer disinfected effluent, dewater and wash down chlorine contact basin.
    - 3) Mobilize and install scaffolding and concrete removal equipment.
    - 4) Remove conflicting process piping.
    - 5) Perform concrete removal and expansion joint material removal.
    - 6) Perform crack repair, controlled concrete surface rehabilitation, concrete joint cleaning and resealing. This structural repair Work may be performed as a separate chlorine basin removal from service, or concurrently with mechanical, associated with the basins, provided the basins are returned to service within the timeframe provided herein.
    - 7) Install and test repair mortar.
    - 8) Replace process piping as required.
    - 9) Demobilize and remove equipment; return basin to service in coordination with Owner.
    - 10) Once each basin meets Substantial Completion requirements, Owner will operate those facilities.
  - c. Final Treatment Effluent Improvements:
    - 1) Coordinate with Owner to complete taking basin offline and lockout/tag out procedure.
    - 2) Install temporary and quickly removable bulkheads in chlorine contact basin to isolate and allow Contractor dewatering of channel.
    - 3) Install and commission temporary bypass pumping system as required to support final treatment influent channel rehabilitation.

MWMC PRIMARY CLARIFIER AND  
FINAL TREATMENT CONCRETE REPAIR

- 4) Transfer disinfected effluent, dewater and wash down effluent channel.
  - 5) Mobilize and install scaffolding and concrete removal equipment.
  - 6) Perform concrete removal and expansion joint material removal and replacement.
  - 7) Replace W2 pump station screens as required.
  - 8) Demobilize and remove equipment; return basin to service in coordination with Owner.
  - 9) Once the channel meets Substantial Completion requirements, Owner will operate those facilities.
- d. Primary Clarifier Launder Improvements:
- 1) Coordinate with Owner to complete taking basin offline and lockout/tag out procedure.
  - 2) Transfer clarifier effluent, dewater and wash down clarifier launder.
  - 3) Remove and collect detailed measurements for accurate reinstallation of clarifier cover and clarifier mechanisms parts and pieces (including and not limited weir plate and scum baffle) as needed in coordination with Owner and operations staff.
  - 4) Mobilize and install scaffolding and concrete removal equipment.
  - 5) Remove conflicting process piping.
  - 6) Perform concrete removal and expansion joint material removal.
  - 7) Perform crack repair, controlled concrete surface rehabilitation, concrete joint cleaning and resealing. This structural repair Work may be performed as a separate chlorine basin removal from service, or concurrently with mechanical, associated with the clarifiers, provided the clarifiers are returned to service within the timeframe provided herein.
  - 8) Install and test repair mortar.
  - 9) Apply epoxy coating.
  - 10) Replace and recoat process piping.
  - 11) Replace process piping as required.
  - 12) Reinstall clarifier cover and clarifier mechanisms parts and pieces (including and not limited weir plate and scum baffle).
  - 13) Demobilize and remove equipment; return basin to service in coordination with Owner.
  - 14) Once each primary clarifier meets Substantial Completion requirements, Owner will operate those facilities.

MWMC PRIMARY CLARIFIER AND  
FINAL TREATMENT CONCRETE REPAIR

1.06 FACILITY OPERATIONS

- A. Continuous operation of Owner's facilities is of critical importance. Schedule and conduct activities such that the existing plant remains in continuous satisfactory operation during the entire construction period, unless otherwise specified.
- B. Perform Work continuously during critical connections and changeovers, and as required to prevent interruption of Owner's operations.
- C. Overnight sleeping on the Water Pollution Control Facility (WPCF) grounds will not allowed without written approval.
- D. The Plant has specific safety procedures that require all workers to attend a 1-hour (or less) orientation and training session. Topics will include: accessing the Site during off-hours, designated work areas, plant safety. Contractor's Superintendent(s) and Foremen must attend this training prior to work commencing onsite. Contractor must review this information with all subcontractors and new workers prior to the commencement of their work. Contractor must confirm with written documentation that subcontractors have reviewed the onsite rules. Annual refresher training is required.
- E. When necessary, plan, design, and provide various temporary services, utilities, connections, temporary piping and heating, access, and similar items to maintain continuous operations of Owner's facility.
- F. Do not close lines, open or close valves, or take other action which would affect the operation of existing systems, except as specifically required by the Contract Documents and after authorization by Owner. Such authorization will be considered within 48 hours after receipt of Contractor's written request.
- G. Spills:
  - 1. Spills of untreated or partially treated sewage to surface waters or drainage courses are prohibited during construction. In the event accidental spill is caused by Contractor's operations, Owner shall immediately be entitled to employ others to stop the spill without giving written notice to Contractor.

MWMC PRIMARY CLARIFIER AND  
FINAL TREATMENT CONCRETE REPAIR

2. Penalties imposed on Owner as a result of any bypass caused by actions of the Contractor, his employees, or subcontractors, shall be borne in full by Contractor, including legal fees and other expenses to Owner resulting directly or indirectly from the bypass. Under the terms of discharge permits issued to Owner, in the event accidental bypassing occurs, Owner is liable for the following civil penalties:
    - a. NPDES Permit No. 102486.
    - b. 32,500 dollars per day.
  3. A spill is defined as 1-gallon or more of any wastewater process stream, except disinfected plant effluent.
  4. In the event of a spill or sanitary sewer overflow which could result in land, ground water, storm water, waterway, or other exposure to the public, Contractor must notify Owner immediately. The following information shall be provided by Contractor:
    - a. Date/Time the spill started.
    - b. Date/Time the spill stopped.
    - c. Estimated total volume released.
    - d. What caused or led to the release.
    - e. What will prevent reoccurrences.
  5. Owner will endeavor to assist Contractor to stop the spill to extent possible. However, all labor, materials, equipment, fines incurred by Owner will be deducted from the next pay request or retainage of Contractor.
  6. Any cleanup and restoration deemed necessary by Owner will be performed by Contractor at Contractor's expense.
- H. Contractor must provide Owner with advance written notifications prior to starting work as described below:

<b>Description</b>	<b>Advance Notice, working days</b>
Taking any process unit out of service	20
Taking any equipment out of service	10
Taking portions of power, water or air systems out of service	5
Creating temporary onsite traffic restrictions	10
Starting groundwater dewatering operations	20
Performing tank or channel dewatering	10
Potholing to locate subsurface utilities and obstructions	3

MWMC PRIMARY CLARIFIER AND  
FINAL TREATMENT CONCRETE REPAIR

Bypassing treatment units	20
Conducting training	21
Conducting testing	10
Requesting special inspections	1

I. Process or Facility Shutdown:

1. The following will require shutdown at some time during the Work:  
Final Effluent channel improvements.
2. No more than one process outage per week, for all active projects, will occur, unless otherwise approved by Owner. To clarify, each Contractor onsite will not be granted one shutdown per week. Rather, one shutdown per week will be accommodated for all projects onsite. Contractor is encouraged to coordinate outage needs with Owner to coincide with other Project activities.
3. When required, process outages shall be performed, as best as possible, during low flow periods. Low flows are between 4:00 a.m. and 7:00 a.m. Process outages shall be a maximum of four hours in duration, of which typically the first 45 minutes is required for flow to actually stop, leaving just over 3 hours of work time.
4. Approval of shutdown may be contingent upon flow or some other factor outside of Owner's control. Owner reserves the right to cancel any scheduled outage if, in their best professional judgment, the outage will cause a violation of the National Pollutant Discharge Elimination System (NPDES) permit.
5. Provide a completed Shutdown Request form in advance to Owner in accordance with Subsection 1.06(H) of this specification section, or, if not listed, 10 working days.
6. For each shutdown, Contractor will identify a Safety Representative who will perform the following:
  - a. Verify, and then notify, the operations console when Contractor's crew and equipment are "all clear" from the shutdown area, and that it is safe to put the equipment back in operation.
  - b. Be onsite throughout the shutdown.
7. 1 week prior to scheduled shutdown, Contractor must meet with the Owner to perform the following:
  - a. Communicate any modifications to the Shutdown Request form.
  - b. Discuss likelihood of shutdown occurring on schedule.
  - c. Will verify that all equipment, tools, temporary power, working platforms, and components necessary for the outage are onsite.
  - d. Clarify roles of Contractor, and Owner's personnel during the shutdown.

MWMC PRIMARY CLARIFIER AND  
FINAL TREATMENT CONCRETE REPAIR

8. 24 hours prior to scheduled shutdown, assist Owner with the following:
  - a. Owner will confirm Contractor is ready to proceed with the shutdown as described on the Shutdown Request form.
  - b. Owner will confirm that prefabrication of all piping and other assemblies are completed, to the greatest degree possible.
9. Provide adequate numbers of personnel for each shutdown, so that the work shall be accomplished within the specified time frame.
10. Install and maintain bypass facilities and temporary connections required to keep WPCF operations on line. Provide temporary provisions for continuous power supply to critical facility components. Sequences other than those specified will be considered upon written request to Owner, provided they afford equivalent continuity of operations.
11. Do not proceed with Work affecting a facility's operation without obtaining Owner's advance written approval of the need for and duration of such Work.
12. Unscheduled shutdown and/or interruptions of continued safe and satisfactory operation of the facility that results in any fines levied shall be the responsibility of Contractor if it is demonstrated that Contractor was negligent in their work or did not exercise proper precautions in the conduct of their work.
13. Whenever possible, combine discrete shutdown procedures into a single shutdown when the duration of the shutdowns or the Work requirements allows such combining to occur on a process unit or work area. The intent of combining procedures is to minimize the impacts upon plant operations and processes by limiting the number of shutdowns required.
14. Contractor must contact Greg Watkins (541) 682-8610, [Greg.A.Watkins@ci.eugene.or.us](mailto:Greg.A.Watkins@ci.eugene.or.us) ) or Owner's Project Manager when shutdowns of existing piping, structures, equipment, electrical, or control systems are required. Contractor must provide the following information.
  - a. Where the work will take place.
  - b. What process piping and/or equipment need to be locked-out.
  - c. When Contractor would like to have the piping and/or equipment locked-out.
  - d. How long the lock-out will be in place.
15. Owner will schedule a time to conduct the lock-out. An Owner representative must be present during any lock-out of Owner's facilities.
16. Owner will endeavor to comply with Contractor requests in a timely manner. However, Contractor is advised that plant operational needs take precedence over construction requests.
17. Contractor is responsible for providing all locks, tags, chains, blocks, and any other devices necessary to safely de-energize and lock-out the process piping and/or equipment.

MWMC PRIMARY CLARIFIER AND  
FINAL TREATMENT CONCRETE REPAIR

18. When Contractor has completed their work, they must contact Greg Watkins and receive verbal approval before removing their lock-out devices. Only Owner is authorized to put process piping or equipment in service.
  19. Contractor must also follow OR-OSHA internal lock-out procedures. If Contractor believes there is a conflict between Owner's Lock-out/Tag-out procedure and their own procedure, Contractor must advise Owner as soon as practical.
  20. Cleaning of a process unit to be taken out of service shall be performed by Owner. Owner shall clean process unit a single time, when unit is first taken out of service. Additional cleaning events must be performed by Contractor. Owner's cleaning operations shall include draining hosing to remove material loosely attached to surfaces. Additional cleaning required by Contractor to perform the Work must be provided by Contractor.
  21. Prepare and submit a detailed Facility Outage Plan when removal of an existing facility from service is necessary to complete the Work. Restrictions on outages are described in this section.
  22. Submit the Facility Outage Plan to the Engineer and Owner for review and approval at least 2 weeks prior to the scheduled outage. Develop the Facility Outage Plan to satisfy the Work Sequence restrictions and conditions specified in this section. Do not proceed with any Work involving facility outages until the Outage Plan has been approved by the Engineer and Owner.
  23. The Facility Outage Plan must describe, as applicable, a listing of existing facilities that will be taken out of service, the length of time required to complete the operation, and the necessary personnel and equipment which will be provided in order to successfully complete the operation.
  24. Coordinate the outage schedule with the overall construction schedule.
- J. Relocation of Existing Facilities:
1. During construction, it is expected that minor relocations of Work will be necessary.
  2. Provide complete relocation of existing structures and Underground Facilities, including piping, utilities, equipment, structures, electrical conduit wiring, electrical duct bank, and other necessary items.
  3. Use only new materials for relocated facility. Match materials of existing facility, unless otherwise shown or specified.
  4. Perform relocations to minimize downtime of existing facilities.
  5. Install new portions of existing facilities in their relocated position prior to removal of existing facilities, unless otherwise accepted by Owner.

MWMC PRIMARY CLARIFIER AND  
FINAL TREATMENT CONCRETE REPAIR

- K. Stage Work to maintain unobstructed access for emergency vehicles to all buildings and fire hydrants.

1.07 ADJACENT FACILITIES AND PROPERTIES

A. Examination:

1. Before onsite work begins Contractor, Owner, and affected property owners and utility owners shall make a thorough examination of pre-existing conditions including existing buildings, structures, and other improvements in vicinity of Work, as applicable, which could be damaged by construction operations.
2. Periodic reexamination must be jointly performed to include, but not limited to, cracks in structures, settlement, leakage, and similar conditions.

B. Documentation:

1. Record and submit documentation of observations made on examination inspections in accordance with Subsection 1.08 of this specification section.
2. Upon receipt, Owner will review, sign, and return one record copy of documentation to Contractor to be kept on file in field office.
3. Such documentation shall be used as indisputable evidence in ascertaining whether and to what extent damage occurred as a result of Contractor's operations, and is for the protection of adjacent property owners, Contractor, and Owner.

1.08 CONSTRUCTION PHOTOGRAPHS

- A. Photographically document all phases of the project including preconstruction, construction progress, and post-construction. Each photo must have date with time stamp and/or method to identify the date and local time that the photo was taken for the Project.
- B. Use digital camera and provide color photos in digital format of not less than 5.0 mega pixels color.
- C. Owner reserves the right to select the subject matter and vantage point from which photographs are to be taken.

MWMC PRIMARY CLARIFIER AND  
FINAL TREATMENT CONCRETE REPAIR

D. Preconstruction and Post-Construction:

1. After Effective Date of the Agreement and before Work at Site is started, and again upon issuance of Substantial Completion, take a minimum of 100 exposures of Construction Site and property adjacent to perimeter of Construction Site. Deliver digital photos to Owner and Engineer on USB storage devices labeled with the project name and number, and upload all photos to the Project Software in an organized method (day/month/year) acceptable to Owner.
2. Particular emphasis shall be directed to structures both inside and outside the Site.

E. Construction Progress Photos:

1. Photographically demonstrate progress of construction, showing every aspect of Site and adjacent properties as well as interior and exterior of new or impacted structures.
2. Weekly: Take minimum 40 exposures using Digital Camera and upload monthly to the Project Software in an organized method (day/month/year) acceptable to Owner.

**PART 2 PRODUCTS (NOT USED)**

**PART 3 EXECUTION**

3.01 SALVAGE OF MATERIALS

- A. Meet with Owner prior to starting to dismantle equipment or piping designated to be salvaged. Owner will indicate locations where equipment is to be disconnected.

3.02 CUTTING, FITTING, AND PATCHING

- A. Cut, fit, adjust, or patch Work and work of others, including excavation and backfill as required, to make Work complete.
- B. Obtain prior written authorization of Owner before commencing Work to cut or otherwise alter:
1. Structural or reinforcing steel, structural column or beam, elevated slab, trusses, or other structural member.
  2. Weather- or moisture-resistant elements.
  3. Efficiency, maintenance, or safety of element.
  4. Work of others.

MWMC PRIMARY CLARIFIER AND  
FINAL TREATMENT CONCRETE REPAIR

- C. Refinish surfaces to provide an even finish.
  - 1. Refinish continuous surfaces to nearest intersection.
  - 2. Refinish entire assemblies.
  - 3. Finish restored surfaces to such planes, shapes, and textures that no transition between existing work and Work is evident in finished surfaces.
- D. Restore existing work, Underground Facilities, and surfaces that are to remain in completed Work including concrete-embedded piping, conduit, and other utilities as specified and as shown.
- E. Make restorations with new materials and appropriate methods as specified for new Work of similar nature; if not specified, use recommended practice of manufacturer or appropriate trade association.
- F. Fit Work airtight to pipes, sleeves, ducts, conduit, and other penetrations through surfaces and fill voids.
- G. Remove specimens of installed Work for testing when requested by Owner.

3.03 PROTECTION OF PUBLIC PROPERTY

- A. Contractor shall employ such means and methods as necessary to adequately protect public and private property and property of the Owner against damage. In the event of damage to such property, Contractor must, at his own expense, immediately restore the property to a condition equal to the original condition and to the satisfaction of the Owner of said property.

3.04 SUPPLEMENT

- A. The supplement listed below, following “End of Section,” is a part of this specification:
  - 1. Shutdown Request Form.

**END OF SECTION**

MWMC PRIMARY CLARIFIER AND  
FINAL TREATMENT CONCRETE REPAIR

**SHUTDOWN REQUEST FORM**

<b>Type of Outage (flow, electrical, control, other)</b>	<b>Detailed Description of Work</b>	<b>Process Units / Equipment Affected, and Operational State During Outage</b>	<b>Duration of Outage</b>	<b>Constraints &amp; Coordination</b>	<b>Safety Representative (name, contact info.)</b>

**SECTION 01 50 00**  
**TEMPORARY FACILITIES AND CONTROLS**

**PART 1 GENERAL**

1.01 REFERENCES

- A. The following is a list of standards which may be referenced in this section:
1. American Association of Nurserymen: American Standards for Nursery Stock.
  2. Federal Emergency Management Agency.
  3. NFPA, National Fire Prevention Standard for Safeguarding Building Construction Operations.
  4. Telecommunications Industry Association (TIA); Electronic Industries Alliance (EIA): 568B, Commercial Building Telecommunications Cabling Standard.
  5. U.S. Department of Agriculture: Urban Hydrology for Small Watersheds.
  6. U.S. Weather Bureau: Rainfall-Frequency Atlas of the U.S. for Durations From 30 Minutes to 24 Hours and Return Periods From 1-Year to 100 Years.

1.02 SUBMITTALS

- A. Informational Submittals:
1. Copies of permits and approvals for construction as required by Laws and Regulations and governing agencies.
  2. Temporary Utility Submittals: Temporary bypass plan.
  3. Temporary Construction Submittals:
    - a. Parking area plans.
    - b. Contractor's field office, storage yard, and storage building plans, including gravel surfaced area.
    - c. Plan for maintenance of existing plant operations.
  4. Temporary Control Submittals:
    - a. Noise control plan.
    - b. Plan for disposal of waste materials and intended haul routes.
    - c. Dust control plan.

MWMC PRIMARY CLARIFIER AND  
FINAL TREATMENT CONCRETE REPAIR

1.03 MOBILIZATION

- A. Mobilization shall include, but not be limited to, these principal items:
  - 1. Obtaining required permits.
  - 2. Moving Contractor's field office and equipment required for first month operations onto Site.
  - 3. Installing temporary construction power, wiring, and lighting facilities.
  - 4. Providing onsite communication facilities, including telephones.
  - 5. Providing onsite sanitary facilities and potable water facilities as specified and as required by Laws and Regulations, and governing agencies.
  - 6. Arranging for and erection of Contractor's work and storage yard.
  - 7. Posting OSHA required notices and establishing safety programs and procedures.
  - 8. Having Contractor's superintendent at Site full time unless otherwise approved by Owner.
- B. Use area designated for Contractor's temporary facilities as shown on the Drawings.

1.04 PROTECTION OF WORK AND PROPERTY

- A. Comply with Owner's safety rules while on Owner's property.
- B. Keep Owner informed of serious onsite accidents and related claims.
- C. No blasting or use of explosives will be allowed onsite.

1.05 VEHICULAR TRAFFIC

- A. Traffic Routing Plan: Show sequences of construction affecting use of roadways, time required for each phase of the Work, provisions for decking over excavations and phasing of operations to provide necessary access, and plans for signing, barricading, and striping to provide passages for pedestrians and vehicles.

MWMC PRIMARY CLARIFIER AND  
FINAL TREATMENT CONCRETE REPAIR

**PART 2 PRODUCTS**

2.01 PROJECT SIGNS

- A. Provide and maintain one, 8-foot wide by 4-foot high sign constructed of 3/4-inch exterior high density overlaid plywood. Sign must bear name of Project, Owner, Contractor, Engineer, and other participating agencies. Lettering must be blue applied on a white background by an experienced sign painter using exterior type enamel. Information to be included will be provided by Owner.
- B. If applicable, provide sign as specified in specification Section 00 73 73, Statutory Requirements for CWSRF-funded Construction Project.

**PART 3 EXECUTION**

3.01 TEMPORARY UTILITIES

- A. Power:
  - 1. Electric power will be available at or near Site for temporary contractor trailer only.
  - 2. For all construction activities, Contractor will determine type and amount available and make arrangements for obtaining temporary electric power service, metering equipment, and pay all costs for electric power used during Contract period, except for portions of the Work designated in writing by Project Manager as substantially complete.
  - 3. Cost of electric power will be borne by Contractor.
- B. Provide temporary lighting to meet applicable safety requirements to allow erection, application, or installation of materials and equipment, and observation or inspection of the Work.
- C. Heating, Cooling, and Ventilating:
  - 1. Provide as required to maintain adequate environmental conditions to facilitate progress of the Work, to meet specified minimum conditions for installation of materials, and to protect materials, equipment, and finishes from damage due to temperature or humidity
  - 2. Provide adequate forced air ventilation of enclosed areas to cure installed materials, to dispense humidity, and to prevent hazardous accumulations of dust, fumes, vapors, or gases.
  - 3. Pay all costs of installation, maintenance, operation, removal, and fuel consumed.

MWMC PRIMARY CLARIFIER AND  
FINAL TREATMENT CONCRETE REPAIR

D. Water:

1. Contractor may use onsite fire hydrant for construction use water at final treatment chlorine contact basins. Hydrant must be fitted with suitable backflow prevention device that has been tested for proper function by certified backflow tester. Provide Owner with valid documentation certifying successful test procedures. Hydrant use must also be metered by Contractor for Owner's purposes to accurately record volume of water used. All water necessary for construction use at the primary clarifiers must be provided by Contractor.
2. Provide water for drinking and culinary use by construction personnel during construction.

E. Sanitary and Personnel Facilities:

1. Provide and maintain facilities for all construction personnel.
2. Obtain Owner's permission before allowing construction personnel to use existing sanitary facilities at Site.

F. Telephone and Email Service: Provide wireless phone and internet services at Site for construction purposes.

G. Furnish and maintain on Site adequate firefighting equipment capable of extinguishing incipient fires. Comply with applicable parts of National Fire Prevention Standard for Safeguarding Building Construction Operations (NFPA No. 241).

3.02 PROTECTION OF WORK AND PROPERTY

A. General:

1. Perform Work within right-of-way and easements in a systematic manner that minimizes inconvenience to property owners and the public.
2. No residence or business shall be cut off from vehicular traffic for a period exceeding 1 hour, unless special arrangements have been made.
3. Maintain in continuous service all existing oil and gas pipelines, underground power, telephone or communication cable, water mains, irrigation lines, sewers, poles and overhead power, and all other utilities encountered along line of the Work, unless other arrangements satisfactory to owners of said utilities have been made.
4. Where completion of the Work requires temporary or permanent removal or relocation of existing utility, coordinate all activities with owner of said utility and perform all work to their satisfaction.

MWMC PRIMARY CLARIFIER AND  
FINAL TREATMENT CONCRETE REPAIR

5. Protect, shore, brace, support, and maintain underground pipes, conduits, drains, and other underground utility construction uncovered or otherwise affected by construction operations.
  6. Keep fire hydrants and water control valves free from obstruction and available for use at all times.
  7. In areas where Contractor's operations are adjacent to or near a utility, such as gas, telephone, television, electric power, water, sewer, or irrigation system, and such operations may cause damage or inconvenience, suspend operations until arrangements necessary for protection have been made by Contractor.
  8. Notify property owners and utility offices that may be affected by construction operation at least 2 days in advance: Before exposing a utility, obtain utility owner's permission. Should service of utility be interrupted due to Contractor's operation, notify proper authority immediately. Cooperate with said authority in restoring service as promptly as possible and bear costs incurred.
  9. Do not impair operation of existing sewer system. Prevent construction material, pavement, concrete, earth, volatile and corrosive wastes, and other debris from entering sewers, pump stations, or other sewer structures.
  10. Maintain original Site drainage wherever possible.
- B. Provide and maintain additional temporary security fences as necessary to protect the Work and Contractor-furnished products not yet installed.
- C. Barricades and Lights:
1. Provide barricades and warning lights as required by latest edition of the Oregon Temporary Traffic Control Handbook and in sufficient quantity to safeguard the public and the Work.
  2. Provide as necessary to prevent unauthorized entry to construction areas and affected roads, streets, and alleyways, inside and outside of fenced area, and as required to ensure public safety and the safety of construction personnel, Owner's personnel, and other who may be affected by the Work.
  3. Locate to enable access by facility operators and property owners.
  4. Protect streets, roads, highways, and other public thoroughfares that are closed to traffic by effective barricades with acceptable warning signs.
  5. Locate barricades at the nearest intersecting public thoroughfare on each side of the blocked section.
  6. Illuminate barricades and obstructions with warning lights from sunset to sunrise.

MWMC PRIMARY CLARIFIER AND  
FINAL TREATMENT CONCRETE REPAIR

D. Trees and Plantings:

1. Protect from damage and preserve trees, shrubs, and other plants outside limits of the Work and within limits of the Work, which are designated on the Drawings to remain undisturbed.
  - a. Where practical, tunnel beneath trees when on or near line of trench.
  - b. Employ hand excavation as necessary to prevent tree injury.
  - c. Do not stockpile materials or permit traffic within drip lines of trees.
  - d. Provide and maintain temporary barricades around trees.
  - e. Water vegetation as necessary to maintain health.
  - f. Cover temporarily exposed roots with wet burlap, and keep burlap moist until soil is replaced around roots.
  - g. No trees, except those specifically shown on the Drawings to be removed, shall be removed without written approval of Project Manager.
  - h. Dispose of removed trees in a legal manner off the Site.
2. Balling and burlapping of trees indicated for replacement shall conform to recommended specifications set forth in the American Standards for Nursery Stock, published by American Association of Nurserymen. All balls shall be firm and intact and made-balls will not be accepted. Handle ball and burlap trees by ball and not by top.
3. In event of damage to bark, trunks, limbs, or roots of plants that are not designated for removal, treat damage by corrective pruning, bark tracing, application of a heavy coating of tree paint, and other accepted horticultural and tree surgery practices.
4. Replace each plant that dies as a result of construction activities.
5. See the Drawings for additional requirements

E. Existing Structures:

1. Where Contractor contemplates removal of small structures such as mailboxes, signposts, and culverts that interfere with Contractor's operations, obtain approval of property owner and Project Manager.
2. Move mailboxes to temporary locations accessible to postal service.
3. Replace items removed in their original location and a condition equal to or better than original.

F. Protect finished floors and concrete floors exposed as well as those covered with composition tile or other applied surfacing.

G. Keep ditches, culverts, and natural drainages continuously free of construction materials and debris.

MWMC PRIMARY CLARIFIER AND  
FINAL TREATMENT CONCRETE REPAIR

- H. Construct, maintain, and operate cofferdams, channels, flume drains, sumps, pumps, or other temporary diversion and protection works. Furnish materials required, install, maintain, and operate necessary pumping and other equipment for the environmentally safe removal and disposal of water from the various parts of the Work. Maintain foundations and parts of the Work free from water.

3.03 TEMPORARY CONTROLS

A. Air Pollution Control:

1. Minimize air pollution from construction operations.
2. Burning of waste materials, rubbish, or other debris is not permitted on or adjacent to Site.
3. Adhere to environmental regulations for dust control and take steps to minimize dust when handling aggregates. Treat or water unpaved vehicle routes and other areas used in construction to prevent dust.
4. Provide and maintain temporary dust-tight partitions, bulkheads, or other protective devices during construction to permit normal operation of existing facilities. Construct partitions of plywood, insulating board, plastic sheets, or similar material. Construct partitions in such a manner that dust and dirt from demolition and cutting will not enter other parts of existing building or facilities. Remove temporary partitions as soon as need no longer exists.

- B. Provide acoustical barriers so noise emanating from tools or equipment will not exceed legal noise levels.

C. Water Pollution Control:

1. Divert sanitary sewage and nonstorm waste flow interfering with construction and requiring diversion to sanitary sewers. Prevent overflows to existing waterway.
2. Prior to commencing excavation and construction, obtain Owner's approval of detailed plans showing procedures intended to handle and dispose of sewage, groundwater, and stormwater flow, including dewatering pump discharges.
3. Comply with procedures outlined in U.S. Environmental Protection Agency manuals entitled, "Guidelines for Erosion and Sedimentation Control Planning" and "Implementation, Processes, Procedures, and Methods to Control Pollution Resulting from All Construction Activity."

MWMC PRIMARY CLARIFIER AND  
FINAL TREATMENT CONCRETE REPAIR

4. Comply with state and local requirements including but not limited to the:
    - a. Construction Site Management Plan (CSMP) General Notes.
    - b. Erosion Prevention Permit Application.
    - c. General Permit Form, NPDES Stormwater Discharge Permit (<https://www.oregon.gov/deq/wq/Documents/1200CPermit.pdf>)
  5. Do not dispose of volatile wastes such as mineral spirits, oil, chemicals, or paint thinner in storm or sanitary drains, streams or waterways. Provide acceptable containers for collection and disposal of waste materials, debris, and rubbish.
- D. Erosion, Sediment, and Flood Control:
1. Provide, maintain, and operate temporary facilities to control erosion and sediment releases, and to protect the Work and existing facilities from flooding during construction period.
  2. Design erosion and sediment controls to handle peak runoff resulting from 25-year, 24-hour storm event based on U.S. Weather Bureau, "Rainfall-Frequency Atlas of the United States for Durations from 30 Minutes to 24 Hours and Return Periods from 1-Year to 100 Years," Technical Paper No. 40, 1981.
  3. Size temporary stormwater conveyances based on procedures presented in U.S. Department of Agriculture, "Urban Hydrology for Small Watersheds," Soil Conservation Service Engineering Technical Release No. 55, 1986.
  4. Design temporary flood control facilities for design flood with minimum of 3 feet of freeboard. Design flood shall be as published by FEMA for 100-year recurrence interval.

3.04 STORAGE YARDS AND BUILDINGS

- A. Coordinate requirements with Section 01 60 00, Product Requirements.
- B. Storage of materials must comply with all requirements of the Fire Marshall.
- C. As needed, construct temporary storage yards for storage of products that are not subject to damage by weather conditions.
- D. Temporary Storage Buildings:
  1. Provide environmental control systems that meet recommendations of manufacturers of equipment and materials stored.

MWMC PRIMARY CLARIFIER AND  
FINAL TREATMENT CONCRETE REPAIR

2. Arrange or partition to provide security of contents and ready access for inspection and inventory.
3. Store combustible materials (paints, solvents, fuels) in a well-ventilated and remote building meeting safety standards.

3.05 ACCESS ROADS

- A. Construct access roads as shown and within easements, rights-of-way, or Project limits. Utilize existing roads where shown.
- B. Maintain drainage ways. Install and maintain culverts to allow water to flow beneath access roads. Provide corrosion-resistant culvert pipe of adequate strength to resist construction loads.
- C. Provide gravel, crushed rock, or other stabilization material to permit access by all motor vehicles at all times.
- D. Maintain road grade and crown to eliminate potholes, rutting, and other irregularities that restrict access.
- E. Coordinate detours and other operations affecting traffic and access with Owner. Provide at least 72 hours' notice to Owner when operations will alter access to the Site.
- F. Upon completion of construction, restore ground surface disturbed by access road construction to original grade. Leave access roads in condition suitable for future use by Owner. Replace damaged or broken culverts with new culvert pipe of same diameter and material.

3.06 PARKING AREAS

- A. Control vehicular parking to preclude interference with public traffic or parking, access by emergency vehicles, Owner's operations, or construction operations.
- B. Provide parking facilities for personnel working on the Project. No employee or equipment parking will be permitted on Owner's existing paved areas, except as specifically designated for Contractor's use.
- C. Use Contractor staging areas designated on the Drawings for parking of personal vehicles driven by construction personnel.

MWMC PRIMARY CLARIFIER AND  
FINAL TREATMENT CONCRETE REPAIR

3.07 VEHICULAR TRAFFIC

- A. Comply with Laws and Regulations regarding closing or restricting use of public streets or highways. No public or private road shall be closed, except by written permission of proper authority. Ensure the least possible obstruction to traffic and normal commercial pursuits.
- B. Conduct the Work to interfere as little as possible with public travel, whether vehicular or pedestrian.
- C. Whenever it is necessary to cross or obstruct roads, driveways, and walks, whether public or private, provide and maintain suitable and safe bridges, detours, or other temporary expedients for accommodation of public and private travel.
- D. Coordinate traffic routing with that of others working in same or adjacent areas.

3.08 CLEANING DURING CONSTRUCTION

- A. Clean hard surface roadways and Site in accordance with specification Section 00 72 00, General Conditions of the Contract, as specified in other specification sections, and as required herein.
- B. Wet down exterior surfaces prior to sweeping to prevent blowing of dust and debris. At least weekly, sweep all floors (basins, tunnels, platforms, walkways, roof surfaces), and pick up all debris and dispose.
- C. Provide approved containers for collection and disposal of waste materials, debris, and rubbish. Remove waste material, debris and rubbish from Site at least weekly.
- D. At least weekly, brush sweep entry drive and roadways, and all other streets and walkways affected by the Work and where adjacent to the Work.

**END OF SECTION**

**SECTION 03 01 32**  
**REPAIR OF VERTICAL AND OVERHEAD CONCRETE SURFACES**

**PART 1 GENERAL**

1.01 REFERENCES

- A. The following is a list of standards which may be referenced in this section:
1. American Association of State Highway and Transportation Officials (AASHTO): T277, Standard Method of Test for Electrical Indication of Concrete's Ability to Resist Chloride Ion Penetration.
  2. American Concrete Institute (ACI):
    - a. 301, Specifications for Structural Concrete.
    - b. 506.2, Specification for Shotcrete.
  3. ASTM International (ASTM):
    - a. A615/A615M, Standard Specification for Deformed and Plain Carbon-Steel Bars for Concrete Reinforcement.
    - b. A1064/A1064M, Standard Specification for Carbon-Steel Wire and Welded Wire Reinforcement, Plain and Deformed, for Concrete.
    - c. A706/A706M, Standard Specification for Low-Alloy Steel Deformed and Plain Bars for Concrete Reinforcement.
    - d. C42/C42M, Standard Test Method for Obtaining and Testing Drilled Cores and Sawed Beams of Concrete.
    - e. C78/C78M, Standard Test Method for Flexural Strength of Concrete (Using Simple Beam with Third-Point Loading).
    - f. C109/C109M, Standard Test Method for Compressive Strength of Hydraulic Cement Mortars (Using 2-inch or [50-mm] Cube Specimens).
    - g. C157/C157M, Standard Test Method for Length Change of Hardened Hydraulic-Cement Mortar and Concrete.
    - h. C293/C293M, Standard Test Method for Flexural Strength of Concrete (Using Simple Beam with Center-Point Loading).
    - i. C348, Standard Test Method for Flexural Strength of Hydraulic-Cement Mortars.
    - j. C469, Standard Test Method for Static Modulus of Elasticity and Poisson's Ratio of Concrete in Compression.
    - k. C496/C496M, Standard Test Method for Splitting Tensile Strength of Cylindrical Concrete Specimens.

## MWMC PRIMARY CLARIFIER AND FINAL TREATMENT CONCRETE REPAIR

- l. C531, Standard Test Method for Linear Shrinkage and Coefficient of Thermal Expansion of Chemical-Resistant Mortars, Grouts, Monolithic Surfacing, and Polymer Concretes.
  - m. C596, Standard Test Method for Drying Shrinkage of Mortar Containing Hydraulic Cement.
  - n. C666/C666M, Standard Test Method for Resistance of Concrete to Rapid Freezing and Thawing.
  - o. C882/C882M, Standard Test Method for Bond Strength of Epoxy-Resin Systems Used with Concrete by Slant Shear.
  - p. C928/C928M, Standard Test Method for Bond Strength of Epoxy-Resin Systems Used with Concrete by Slant Shear.
  - q. C1012/C1012M, Standard Test Method for Length Change of Hydraulic-Cement Mortars Exposed to a Sulfate Solution.
  - r. C1202, Standard Test Method for Electrical Indication of Concrete's Ability to Resist Chloride Ion Penetration.
  - s. C1583/C1583M, Standard Test Method for Tensile Strength of Concrete Surfaces and the Bond Strength or Tensile Strength of Concrete Repair and Overlay Materials by Direct Tension (Pull-off Method).
  - t. D638, Standard Test Method for Tensile Properties of Plastics.
  - u. D695, Standard Test Method for Compressive Properties of Rigid Plastics.
  - v. D4258, Standard Practice for Surface Cleaning Concrete for Coating.
  - w. D4259, Standard Practice for Abrading Concrete.
  - x. E699, Standard Practice for Evaluation of Agencies Involved in Testing, Quality Assurance, and Evaluating of Building Components.
4. International Concrete Repair Institute (ICRI): 310.2, Selecting and Specifying Concrete Surface Preparation for Sealers, Coatings, Polymer Overlays, and Concrete Repair with CSP Chips.
  5. Jacobs STEP Team GMP1 Technical Memorandum, Aeration Basin Rehabilitation Product Prequalification.

### 1.02 DEFINITIONS

- A. Abrasive Blasting: Surface preparation method that uses compressed air intermixed with an abrasive medium to clean surface of substrate concrete, exposed steel, and steel reinforcement. Compressed air and abrasive medium is projected at high speed through a nozzle directly at the surface. Method is used to remove corrosion by-products, laitance, or other materials that may inhibit bond of repair concrete.

MWMC PRIMARY CLARIFIER AND  
FINAL TREATMENT CONCRETE REPAIR

- B. Defective Area:
1. At exposed concrete, defective areas also include texture irregularities, stains, and other color variations that cannot be removed by cleaning.
  2. Cold joints.
  3. Surface defects that include honeycomb, rock pockets, indentations, and surface voids greater than 3/16-inch deep, surface voids greater than 3/4-inch in diameter, cracks in liquid containment structures and belowgrade habitable spaces that are 0.005-inch wide and wider, and cracks in other structures with visible leakage or that are 0.010-inch wide and wider, spalls, chips, embedded debris, sand streaks, mortar leakage from form joints, deviations in formed surface that exceed specified tolerances and include but are not limited to fins, form pop-outs, and other projections.
- C. High-Pressure Water Blasting: Sometimes referred to as hydro-demolition. Uses water that may contain an abrasive medium, projected under high pressure and high velocity. Used for demolition, cutting, partial or full depth removal, cleaning, scarifying, or roughening of concrete surfaces, or removing existing coatings, for preparation of substrate concrete surfaces.
- D. Low-Pressure Spray Mortar: Mortar suitable to be applied by low-pressure spraying, and in small areas may be applied by hand troweling.
- E. New Concrete: Concrete less than 60 days old forming structures constructed as part of the Work.
- F. Rebound: Shotcrete material, mostly aggregates, that bounce off a surface against which shotcrete was projected.
- G. Shotcrete: Mortar pumped through hose and projected at high velocity.
- H. Submerged: Location at or below top of wall of open water-holding structure, such as a basin or channel, or wall, ceiling, or floor surface inside a covered water-holding structure, or exterior belowgrade wall or roof surface of water-holding structure, open or covered.
- I. Surface Void Ratio (SVR): The ratio of the total surface void area to the total concrete surface area after stripping forms and no subsequent applied surface treatment.
- J. Unsound Concrete: Concrete with a pH less than 10, concrete that is deteriorating, carbonated, honeycombed, chloride content less than

# MWMC PRIMARY CLARIFIER AND FINAL TREATMENT CONCRETE REPAIR

0.25 percent, otherwise defective, or which sounds hollow when sounded, as determined by Owner.

## 1.03 SUBMITTALS

### A. Action Submittals:

1. Product data sheets for each material supplied.
2. Samples: Mesh reinforcement and mesh anchor.
3. Product data sheet and description of operation for high-pressure water blasting equipment. Include description of how equipment will be adjusted to account for varying concrete strength and hardness.
4. Procedure for installing pins to track the existing concrete surface and procedure for placing piano wire to verify final finish thickness.
5. Procedure for protecting adjacent surfaces that are not subject to repair.

### B. Informational Submittals:

1. Repair Mortar System Option: Manufacturer's preparation and installation instructions.
2. Mesh manufacturer's installation instructions and allowable load criteria.
3. Written description of equipment proposed for concrete removal and surface preparation.
4. Written description of equipment proposed for repair mortar installation.
5. Certificates:
  - a. Shotcrete Nozzleman: Current ACI Certification for each proposed nozzleman.
  - b. Mortar Manufacturer's Certificate of Proper Installation.
6. Statements of Qualification:
  - a. Contractor.
  - b. Contractor's superintendent.
  - c. Hydrodemolition Contractor.
  - d. Hydrodemolition superintendent.
  - e. Repair mortar system applicator.
  - f. Repair mortar system manufacturer's representative.
  - g. Independent Testing Laboratory.
7. Field and Laboratory Test Reports:
  - a. Compression test reports.
  - b. Tension test reports.
  - c. pH test reports. Submit field pH test reports weekly.
  - d. Letter from repair mortar manufacturer's representative stating that the surface preparation is adequate for the repair mortar.

MWMC PRIMARY CLARIFIER AND  
FINAL TREATMENT CONCRETE REPAIR

8. Confirmation bonding agent conforms to ASTM standards.
9. Written description of expected waste during the application of shotcrete or low-pressure spray mortar repair systems.

1.04 QUALITY ASSURANCE

A. Qualifications:

1. Contractor: Successfully completed to Client's satisfaction three projects of similar size and complexity within the last 5 years.
2. Contractor's Superintendent: Superintendent of a minimum of two of the projects used to qualify Contractor.
3. Hydrodemolition Contractor: Successfully completed to Client's satisfaction three projects of similar size and complexity within the last 5 years.
4. Hydrodemolition Contractor's Superintendent: Superintendent of a minimum of two of the projects used to qualify Contractor.
5. Repair Mortar System Applicator:
  - a. For Repair System A – Shotcrete Mortar, trained and experienced applicator recognized or certified by repair mortar system manufacturer.
  - b. For Repair System B and System C – Low-Pressure Spray Mortar, in lieu of recognition or certification, demonstrate application of repair mortar manufacturer's system and obtain Certification of Proper Installation, in accordance with Article Manufacturer's Services.
6. Repair Mortar System Manufacturer's Representative: Knowledgeable and experienced on technical data and application requirements for specified products.

B. Independent Testing Laboratory: Meet criteria stated in ASTM E699.

C. Demonstration Mockup for Repair System Option A – Shotcrete Mortar and Repair System Option B – Low-Pressure Spray Mortar Repair System:

1. For each noted type of repair mortar system to be used, prepare one demonstration repair of at least 10 feet long by full wall height in the Final Treatment facility as coordinated with Owner.
2. Repair Mortar System Manufacturer's Demonstration:
  - a. Schedule time for manufacturer's demonstration of repair system proposed for Project.
  - b. Install measurement system at centerline of demonstration area in accordance with Subsection 1.05 of this specification section.

MWMC PRIMARY CLARIFIER AND  
FINAL TREATMENT CONCRETE REPAIR

- c. Prepare concrete surface of the demonstration area in accordance with Subsection 3.04 through Subsection 3.06 of this specification section.
  - d. Surface preparation must be accepted by manufacturer's representative for each type of application.
  - e. Prepare mortar to specified consistency for testing and placement.
  - f. Cure portions of each type of surface to be repaired using proposed curing procedure and materials, including overhead and vertical applications.
  - g. Demonstrate the following:
    - 1) Mixing and application equipment capabilities and procedures, including flow of material from nozzle or sprayer.
    - 2) Nozzle operator and person in charge of low-pressure sprayer, capabilities and ability to follow prescribed application procedures and properly operate equipment and apply surface repair materials.
  - h. Compression Strength Test: Testing company must make compression test samples from wet mortar during demonstration placement and deliver to independent testing laboratory for testing at 7 days and 28 days.
  - i. Tensile Bond Test: Test in situ or take a core of demonstration placement and test as specified herein below for tensile bond at 7 days as specified in Paragraph Direct Tension Bond Test.
- D. Where Required by Engineer, demonstration Mockup for Repair System Option C – Polymer Modified Repair Mortar System:
- 1. Prepare one demonstration repair of at least 10 feet long by full wall height in the Final Treatment facility as coordinated with Owner.
  - 2. Repair Mortar System Demonstration:
    - a. Schedule time for demonstration of repair system proposed for Project.
    - b. Install measurement system at centerline of demonstration area in accordance with Subsection 1.05 of this specification section.
    - c. Prepare concrete surface of the demonstration area in accordance with Subsection 3.04 through Subsection 3.06 of this specification section.
    - d. Surface preparation must be accepted by manufacturer's representative for each type of application.
    - e. Prepare mortar to specified consistency, for testing and placement.

MWMC PRIMARY CLARIFIER AND  
FINAL TREATMENT CONCRETE REPAIR

- f. Cure portions of each type of surface to be repaired using proposed curing procedure and materials, including overhead and vertical applications.
- g. Demonstrate mixing and application procedures.
- h. Compression Strength Test: Make compression test samples from wet mortar during demonstration placement and deliver to independent testing laboratory for testing at 7 days and 28 days.
- i. Tensile Bond Test: Test in situ or take a core of demonstration placement and test for tensile bond at 7 days as specified in Paragraph Direct Tension Bond Test.

E. Prerepair Conference:

- 1. Required Meeting Attendees:
  - a. Contractor.
  - b. Repair Subcontractor.
  - c. Technical representative for repair material manufacturer.
  - d. Engineer.
  - e. Testing agency.
  - f. Owner.
- 2. Schedule and conduct prior to incorporation of respective products into Project. Notify Engineer and Owner of location and time.
- 3. Agenda must include, but not limited to:
  - a. Review of field conditions. Conduct field observations of the Work to be performed.
  - b. Based on above observations, repair material manufacturer's technical representative must confirm material selection and make Project specific repair method recommendations.
  - c. Technical representative for repair material manufacturer must review proposed surface preparation, material application, consolidation, finishing, curing, and protection of repair material from weather conditions.
  - d. Review of protection measures for adjacent surfaces not subject to repair.
  - e. Other specified requirements requiring coordination.

1.05 MEASUREMENT AND PAYMENT

- A. Measurement for vertical and overhead concrete surface removal and repair pay items must be determined per the following procedure:
  - 1. Prior to removal of existing concrete, install 1/4-inch diameter Type 316, stainless steel rods into face of existing walls (at right angle

MWMC PRIMARY CLARIFIER AND  
FINAL TREATMENT CONCRETE REPAIR

to wall) in a vertical row at 20 feet on center horizontally. Each vertical row must consist of three anchor rods equally spaced. The rods must be located 12 inches below top of wall, mid-height of the wall, and 12 inches above bottom of wall. Drill and epoxy these stainless steel rods a minimum of 3 inches into the existing wall.

2. After installation of steel rods, cut rods flush with the face of existing concrete. Rods will subsequently be used for measurement purposes. Prior to rod placement, Contractor must prepare a rod layout grid with grid naming convention to allow uniform reference to each area of concrete repair and submit for Engineer's approval. All measurement and payment must follow this rod layout and naming convention.
3. Remove existing concrete as indicated herein.
4. Following removal of existing concrete, install additional, new 1/4-inch diameter x minimum 6-inch long Type 316 stainless steel rods 12 inches away from and adjacent to all existing rods. Cover rod ends with rubber bulb to reduce risk of accidental injury after installation. Drill and epoxy new rods a minimum of 3 inches beyond face of demolished concrete. String a steel piano wire between the new rods at the depth of the original existing concrete surface (i.e., with piano wire just touching end of rods placed flush with original concrete surface) and to meet the tolerances listed herein.
5. Screed final product as indicated to original existing concrete surface profile unless a maximum of 1/2-inch of additional build out is required to provide a minimum of 2 inches of clearance over exposed reinforcing.
6. Payment for removal will be based upon measured thickness of removed concrete at rods. The thickness will be determined by averaging the measured depth of removal over each 100-square foot area to determine total quantities for each pay item.
7. Payment for installation of repair will be based upon the measured thickness determined for removal of each 100-square foot area plus any anticipated build out to provide clearance over exposed reinforcing as described in this section. The thickness will be determined by averaging the measured depth of application over each 100-square foot area to determine total quantity for payment.
8. Contractor may submit alternate methods of measurement subject to Owner and Engineer's approval.
9. Pay Items and Unit of Measurement:
  - a. Vertical and Overhead Concrete Surface Removal and Repair; Square Foot:
    - 1) 0-Inch to Expected Depth Noted on the Drawings Removal Depth and Repair Layer Thickness: Lump Sum.

MWMC PRIMARY CLARIFIER AND  
FINAL TREATMENT CONCRETE REPAIR

- 2) Expected Depth to Expected Depth Plus 1/2-Inch Removal Depth and Repair Layer Thickness: Unit Price.
- 3) Greater Than Expected Depth Plus 1/2-Inch Removal Depth and Repair Layer Thickness Where Approved by Engineer: Unit Price.
- 4) Greater Than Expected Depth Plus 1/2-Inch Removal Depth and Repair Layer Thickness Where Not Approved by Engineer: Considered Contractor's means and methods and will not be paid.

1.06 DELIVERY, STORAGE, AND HANDLING

- A. Package repair mortar system products in moisture-resistant bags, pails, or moisture-resistant bulk bags.
- B. Deliver, store, and handle repair materials in accordance with manufacturer's printed instructions.

1.07 EXISTING FACILITIES

- A. Clarifier Rehabilitation:
  1. Prior to turnover to the Contractor, Owner will drain and wash down the Clarifier launder, removing residual sludge, grit, and scum on the walls. Wash down water will be drained from the launder by Owner, leaving less than 4 inches of standing water remaining. Contractor must provide final cleaning prior to allowing entry of personnel into the basins.
  2. Dispose of water onsite after handover from Owner. Coordinate with plant staff for disposal requirements. Any water containing chemicals utilized by Contractor in performance of the Work must be disposed of offsite. See supplement to this specification section.
  3. Coordinate removal and re-installation of the clarifier covers as required.
  4. Protect existing clarifier coatings on the main clarifier slab and walls.
- B. Final Treatment Rehabilitation:
  1. Prior to turnover to the Contractor, Owner will drain and wash down the basin, removing residual sludge, grit, and scum on the walls. Wash down water will be drained from the channel by Owner, leaving less than 4 inches of standing water remaining. Contractor must provide final cleaning prior to allowing entry of personnel into the basins.
  2. Dispose of water onsite after handover from Owner. Coordinate with plant staff for disposal requirements. Any water containing chemicals

MWMC PRIMARY CLARIFIER AND  
FINAL TREATMENT CONCRETE REPAIR

utilized by Contractor in performance of the Work must be disposed of offsite. See supplement to this specification section.

**PART 2 PRODUCTS**

2.01 REPAIR SYSTEM A – SHOTCRETE MORTAR

A. Mortar Materials:

1. Blend of selected portland cements, microsilica, and specially graded aggregates and fibers applicable for vertical and overhead surfaces.
2. Materials must not contain asbestos, chlorides, nitrates, added gypsum, added lime, or high aluminum cements.
3. Noncombustible before and after cure.
4. Furnish in factory proportioned unit.
5. Workability from 1/4-inch in depth and greater.

B. Mixed Mortar Properties:

1. Working Time: 5 minutes to 10 minutes.
2. Finishing Time: 10 minutes to 20 minutes.
3. Color: Dark gray.

C. Cured Mortar Properties:

1. Compressive strength for 2-inch cubes in accordance with ASTM C109/C109M, or 3-inch cubes in accordance with manufacturer's modification to ASTM C109/C109M:
  - a. 7 Days: 4,000 pounds per square inch minimum.
  - b. 28 Days: 6,000 pounds per square inch minimum.
2. Flexural Strength (Modulus of Rupture), ASTM C78/C78M or ASTM C348 (Modified) at 28 Days: 750 pounds per square inch minimum.
3. Splitting Tensile Strength, ASTM C496/C496M at 28 Days: 400 pounds per square inch minimum.
4. Slant Shear Bond Strength, ASTM C882/C882M Test Method Modified with No Bonding Agent, at 28 Days: 2,000 pounds per square inch minimum.
5. Drying Shrinkage, ASTM C157/C157M Modified at 28 Days or ASTM C531: 0.1 percent maximum.
6. Chloride Ion Permeability Based on Charge Passed, ASTM C1202: 1,100 coulombs maximum.
7. Mortar must not produce a vapor barrier.

MWMC PRIMARY CLARIFIER AND  
FINAL TREATMENT CONCRETE REPAIR

- D. Mortars that exceed the 1,100 coulombs maximum chloride ion permeability requirement on submerged surfaces must be coated with an epoxy.

2.02 REPAIR SYSTEM B – LOW-PRESSURE SPRAY MORTAR

- A. One-component or two-component, cement based, fiber reinforced, shrinkage compensated, gray in color, with a minimum 30-minute working time.
- B. Cured materials mixed in accordance with manufacturer’s instructions must conform to the following criteria:
  - 1. Compressive Strength, ASTM C109/C109M at 7 Days: 4,000 pounds per square inch minimum.
  - 2. Compressive Strength, ASTM C109/C109M at 28 Days: 6,000 pounds per square inch minimum.
  - 3. Flexural Strength, ASTM C348 at 28 Days: 750 pounds per square inch minimum.
  - 4. Slant Shear Bond Strength, ASTM C882/C882M Test Method Modified with No Bonding Agent, at 28 Days: 2,000 pounds per square inch minimum.
  - 5. Splitting Tensile Strength, ASTM C496/C496M at 28 Days: 400 pounds per square inch minimum.
  - 6. Drying Shrinkage, ASTM C157/C157M Modified at 28 Days or ASTM C531: 0.1 percent maximum.
  - 7. Chloride Ion Permeability Based on Charge Passed, ASTM C1202: 1,100 coulombs maximum.
  - 8. System must not produce a vapor barrier.
  - 9. Sprayable, extremely low permeability, sulfate resistant, easy to use and requiring only addition of water.
  - 10. Free of chlorides and other chemicals causing corrosion.
- C. Mortars that exceed the 1,100 coulombs maximum chloride ion permeability requirement on submerged surfaces must be coated with an epoxy.

2.03 REPAIR SYSTEM C – POLYMER-MODIFIED REPAIR MORTAR

- A. Polymer-modified, one-component or two-component, cementitious based, chloride resistant, flowable, gray in color, working time of 20 minutes minimum, surface renovation mortar.
- B. Cured Mortar Properties:
  - 1. Compressive Strength, ASTM C109/C109M at 7 Days: 4,000 pounds per square inch minimum.

## MWMC PRIMARY CLARIFIER AND FINAL TREATMENT CONCRETE REPAIR

2. Compressive Strength, ASTM C109/C109M at 28 Days: 6,000 pounds per square inch minimum.
  3. Flexural Strength, ASTM C348 at 28 Days: 750 pounds per square inch minimum.
  4. Slant Shear Bond Strength, ASTM C882/C882M Test Method Modified with No Bonding Agent, at 28 Days: 2,000 pounds per square inch minimum.
  5. Splitting Tensile Strength, ASTM C496/C496M at 28 Days: 400 pounds per square inch minimum.
  6. Drying Shrinkage, ASTM C157/C157M Modified at 28 Days or ASTM C531: 0.1 percent maximum.
  7. Chloride Ion Permeability Based on Charge Passed, ASTM C1202: 1,100 coulombs maximum.
  8. System must not produce a vapor barrier.
- C. Mortars that exceed the 1,100 coulombs maximum chloride ion permeability requirement on submerged surfaces must be coated with an epoxy.

### 2.04 WATER

- A. Clean and free from oil, acid, alkali, organic matter, or other deleterious substances, meeting federal drinking water standards.

### 2.05 REINFORCEMENT

- A. Deformed Steel Reinforcement:
1. ASTM A615/A615M or ASTM A706/A706M, Grade 60, where welding is not required.
  2. ASTM A706/A706M, Grade 60, for steel reinforcement to be welded.
- B. Tie Wire: 16-gauge, galvanized.

### 2.06 CEMENTITIOUS BONDING AGENT

- A. Cementitious adhesive, specifically formulated for bonding plastic portland cement concrete or mortar to hardened portland cement concrete.
1. Mixed Bonding Agent Properties:
    - a. Pot Life: 75 minutes to 105 minutes.
    - b. Contact Time: 24 hours.

MWMC PRIMARY CLARIFIER AND  
FINAL TREATMENT CONCRETE REPAIR

2. Cured Cementitious Adhesive Properties:
    - a. Splitting Tensile Strength, ASTM C496/C496M at 28 Days: 500 pounds per square inch minimum.
    - b. Flexural Strength, ASTM C348: 1,000 pounds per square inch minimum.
    - c. Slant Shear Bond Strength, ASTM C882/C882M at 14 Days:
      - 1) 2-Hour Open Time: 2,500 pounds per square inch minimum.
      - 2) 24-Hour Open Time: 2,000 pounds per square inch minimum.
  3. Bonding agent must not produce a vapor barrier.
  4. Compatible with and from same manufacturer as the repair system used.
- B. Product must match what was installed in the test repair. Systems that used a bonding agent must use the bonding agent when applied in the Work. The test repair system that did not use a bonding agent must not use a bonding agent when applied in the Work.

2.07 REINFORCING CORROSION INHIBITOR

- A. Cementitious epoxy coating with corrosion inhibitor.
- B. Compatible with repair mortar being used.
- C. Manufacturers and Products:
  1. Sika Chemical Corp., Lyndhurst, NJ; Armatec 110 EpoCem.
  2. Euclid Chemical Co., Cleveland, OH; Duralprep A.C.
  3. Master Builder Solutions, Beachwood, OH; MasterEmaco P124.

2.08 EVAPORATION RETARDANT

- A. As specified in specification Section 03 39 00, Concrete Curing.

2.09 CURING COMPOUND

- A. As specified in specification Section 03 39 00, Concrete Curing. Curing compound must not be used on surfaces that will receive a coating.

2.10 PREMOLDED JOINT FILLER

- A. Bituminous Type: ASTM D994 or ASTM D1751.

# MWMC PRIMARY CLARIFIER AND FINAL TREATMENT CONCRETE REPAIR

## B. Sponge Rubber:

1. Neoprene, closed cell, expanded; ASTM D1056, Type 2C5, with compression deflection, 25 percent deflection (limits), 119 kPa to 168 kPa (17 psi to 24 psi) minimum.
2. Manufacturer and Product: Monmouth Rubber and Plastics, Corp, Long Branch, NJ; Durafoam DK5151.

## 2.11 POURABLE JOINT FILLER OR JOINT SEALANT

A. General: Although product is a sealant, it may be used as a filler to prevent debris accumulation and allow expansion and contraction under shrinkage and thermal loads. It does not need to meet proportional sealant geometry requirements when used as a joint filler.

## B. Filler or Sealant for Potable or Non-Potable Water Containment Structures:

1. Multicomponent sealant, self-leveling, or nonsag as required for level, sloping, or vertical joints.
2. Color: White.
3. Manufacturer and Product: Sika Corp., Lyndhurst, NJ; Sikaflex-2c.

## 2.12 FIELD PH TESTING

### A. Manufacturers and Products:

1. Micro Essential Laboratory, Brooklyn, NY: Hydrion Insta-check 0-13 Mechanical pH pencil.
2. Germann Instruments Inc, Evanston, IL: Rainbow Indicator Spray.
3. Germann Instruments Inc, Evanston, IL: Deep Purple Spray.

## **PART 3 EXECUTION**

### 3.01 GENERAL

A. Existing Concrete Work: Repair concrete as identified in Contract Documents.

### 3.02 APPLICATION

A. Apply repair mortar in accordance with manufacturer's recommendations.

B. Where a mortar pump is used, provide operable backup mortar pump of equal or better performance than the primary mortar pump. Backup pump must be onsite and available at all times. Provide spare parts onsite for commonly broken or worn items to minimize pump down time.

MWMC PRIMARY CLARIFIER AND  
FINAL TREATMENT CONCRETE REPAIR

3.03 SURFACE VOID RATIO EVALUATION AND LIMITS

- A. SVR Evaluation:
1. Void area is the summation of the areas of all voids within a sample space of 24-inch by 24-inch. Voids with an average diameter of less than 3/32-inch are excluded.
  2. Surface void ratio is only required to be determined if the entire impression of the surface does not meet the contract expectation as set by the Mock-up Panels.
- B. SVR Limits:
1. Void area not to exceed 1.2 percent of test area.
  2. Maximum allowed void diameter: 1/2-inch.

3.04 PREPARATION

- A. At the Rehabilitation locations, remove unsound concrete to the minimum depth indicated in the Contract Documents. Using pH field testing and sounding, remove additional concrete with a pH of less than 10. Perform field pH tests per testing product manufacturer's instructions. Perform one test every 25 square feet for the first 3 days of concrete removal and every 250 square feet thereafter. Retest as required to expose concrete with a pH greater than 10. Record the pH at each test location in a log for submittal. Test must be performed within 7 hours of concrete demolition to prevent surface carbonation.
- B. At the Rehabilitation locations, place pins to mark the existing surface prior to commencing hydrodemolition. The surface control pins must be reviewed and verified with the onsite inspector prior to removal of existing surface. Once the existing surface has been removed, verify with the onsite inspector the accuracy of piano wire or equivalent method for the final finish thickness.
- C. Remove unsound concrete from work areas.
1. Use 8,000 pounds per square inch minimum high-pressure water blasting machine as required for Site conditions.
  2. Hydrodemolition equipment and the pressure used must be selected such that the machine operator and the inspector can immediately observe the demolished area and ensure that the maximum demolition depth is not being exceeded. Equipment must be able to account for varying concrete strength and hardness.

MWMC PRIMARY CLARIFIER AND  
FINAL TREATMENT CONCRETE REPAIR

3. Remove concrete to abrade substrate concrete surfaces to a minimum amplitude as required by the repair mortar manufacturer's product literature.
  4. Where final surface is required to be flush with existing adjacent surface remove existing concrete depth as required for application of minimum thickness of repair mortar.
  5. Sound concrete by tapping with maximum 24-ounce mason's hammer after hydrodemolition and remove fins and loose aggregate that were left behind.
  6. Following removal of unsound concrete, check substrate concrete surface by sounding techniques to identify unsound concrete remaining or resulting from use of chipping hammer.
- D. Do not use power-driven jackhammers, chipping hammers, or scabblers unless water blasting is not permitted or practical because of Site conditions or may cause other damage to equipment or facilities. In such cases where chipping hammers are required, limit size of chipping hammer to 16 pounds or lighter, or use small electric chipping hammer, to reduce formation of micro-fractures in substrate concrete surface.
- E. Pressure wash areas with likely surface voids to remove laitance and expose underlying voids.
- F. Remove unsound concrete. Repair system manufacturer's representative, Engineer, or Engineer's representative must confirm that unsound concrete has been removed.
- G. Square edges of patch areas by sawing or chipping to avoid tapered shoulders or feather edges. Avoid cutting embedded steel reinforcement. Roughen polished saw-cut edge by high-pressure water blasting.
- H. Remove concrete adjacent to steel reinforcement to a minimum of 3/4-inch clearance around steel reinforcement for application and bonding of new repair mortar to circumference of exposed steel reinforcement if it is evident that bond between existing concrete and steel reinforcement has been destroyed or has deteriorated as determined by Engineer.
- I. Clean exposed steel reinforcement of loose rust and concrete splatter per recommendations of repair material manufacturer and in accordance with ASTM D4258 and coat with the specified corrosion inhibitor. Do not exceed the manufacturer's open time for the corrosion inhibitor.

MWMC PRIMARY CLARIFIER AND  
FINAL TREATMENT CONCRETE REPAIR

- J. Keep areas from which concrete has been removed free of dirt, dust, and water blasting waste slurry. Remove laitance and other bond inhibiting contamination from prepared areas.
- K. Dampen repair areas at least 6 inches beyond area to receive repair mortar for at least 24 hours to provide saturated surface dry (SSD) condition without standing water at time of application of mortar as required by and in accordance with repair mortar manufacturer's printed instructions.
- L. Collect spent water and concrete debris from removal operations and dispose in a manner and location acceptable to Owner. Water, slurry, and debris with a pH of 5 to 9 may be decanted onsite in coordination with Owner. All solid debris, or materials that are not neutralized to a pH of 5 to 9 and any water containing chemicals utilized by Contractor in performance of the Work must be disposed of offsite. See supplement to this specification section.

3.05 REINFORCEMENT INSTALLATION

- A. Provide steel reinforcement when existing reinforcement is not exposed, and when mortar application is more than 3 inches deep, unless otherwise shown on the Drawings.
- B. Replace deteriorated steel reinforcement that is missing 25 percent or greater of the steel area with new steel reinforcement equivalent in cross-sectional area to the lost sectional area. Extend the new steel reinforcement a lap length past the corroded area. New steel reinforcing must have at least 2-inches of concrete cover after placement of the repair mortar. Coat the new reinforcing with corrosion inhibitive coating.
- C. Provide steel mesh reinforcing and anchors where required by repair mortar manufacturer's installation instructions.
- D. Coat exposed new and existing steel reinforcement with cementitious reinforcement coating at same time as substrate concrete is coated with cementitious bonding agent, as specified below, per repair mortar and cementitious reinforcement coating manufacturers' printed instructions. Ensure the open time of the coating and bonding agent is not exceeded.

3.06 PROTECTION

- A. If cementitious coating, reinforcing corrosion inhibitor, or bonding agent is used, protect adjacent surfaces from over application. Promptly remove cementitious coating, reinforcing corrosion inhibitor, or bonding agent applied beyond repair area.

## MWMC PRIMARY CLARIFIER AND FINAL TREATMENT CONCRETE REPAIR

- B. Protect adjacent surfaces, and equipment from overshooting, rebound, and dust, as applicable for repair mortar system used.
- C. Protect existing expansion joints during hydrodemolition and mortar application. Document the location of expansion joints to ensure no expansion joints are covered during mortar application.

### 3.07 REPAIR SYSTEM A – SHOTCRETE MORTAR PLACEMENT

- A. Apply shotcrete mortar in accordance with manufacturer's instructions.
- B. Track quantity of repair mortar applied by taking depth measurements based on the previously placed piano wire guides. Depth measurement exceeding 1/2 inches beyond approved removal depth, unless authorized by Engineer and Owner, are considered Contractor's means and methods. The number of bags used is not an acceptable measurement of the quantity of mortar applied. The rate of material waste is considered part of the Contractor's means and methods.
- C. Do not reuse rebound materials.
- D. Apply mortar using dry mix process, in accordance with ACI 506.2.
- E. Shotcrete mortar must emerge from nozzle in a steady, uninterrupted flow. If flow becomes intermittent, direct flow away from the Work until flow of mortar becomes constant.
- F. Applied Shotcrete Mortar: Minimum thickness to return wall to original design thickness as noted on the Drawings.
- G. Nozzle Position: Hold nozzle approximately at right angles to and at a distance from surface in accordance with shotcrete repair mortar system manufacturer's instructions for type of application, nozzle, and air pressure used.
- H. Steel Reinforcement Encasement:
  - 1. Modify procedure of shooting shotcrete mortar to better direct material around reinforcement bars.
  - 2. Prevent shotcrete mortar from building up on reinforcement steel when shooting on, around, through, and behind steel to eliminate voids.
  - 3. Provide dense void-free encasement of reinforcement steel.

MWMC PRIMARY CLARIFIER AND  
FINAL TREATMENT CONCRETE REPAIR

- I. Application of multiple layers must be done in accordance with shotcrete repair mortar system manufacturer's printed instructions.
- J. Slice off excess material with a wire screed 5 minutes to 10 minutes after initial set.
- K. Apply smooth form-like finish to exposed shotcrete mortar surface and in accordance with manufacturer's instructions. Apply full strength evaporation retardant.
- L. Remove rebound, sand, and miscellaneous debris continuously throughout shotcrete mortar application, and dispose of offsite at an approved disposal facility.
- M. Cure in accordance with Article Curing of this specification section.

3.08 REPAIR SYSTEM B – LOW-PRESSURE SPRAY MORTAR PLACEMENT

- A. Mix mortar in accordance with manufacturer's printed instructions.
- B. After priming prepared substrate concrete surface per manufacturer's recommendations, apply mortar by low-pressure spraying equipment, unless noted otherwise. At small repair areas, low-pressure spray mortar may be applied by troweling if allowed per the manufacturer's recommendations.
- C. Track quantity of repair mortar applied by taking depth measurements based on the previously placed piano wire guides. Depth measurement exceeding 1/2 inches beyond approved removal depth, unless authorized by Engineer and Owner, are considered Contractor's means and methods. The number of bags used is not an acceptable measurement of the quantity of mortar applied. The rate of material waste is considered part of the Contractor's means and methods.
- D. Bonding Agent:
  - 1. Use bonding agent when used in demonstration repair for hand applied areas, in accordance with repair mortar manufacturer's instructions.
  - 2. Application of repair mortar over bonding agent must be completed within time frame recommended by bonding agent manufacturer.
  - 3. Consult with manufacturer for optimum and minimum acceptable degrees of surface tackiness of coat.
- E. Work mortar firmly and quickly into repair area.

## MWMC PRIMARY CLARIFIER AND FINAL TREATMENT CONCRETE REPAIR

- F. Finish repair mortar to match adjacent concrete surface.
- G. Provide evaporation retardant at full strength.
- H. Cure in accordance with Article Curing of this specification section.

### 3.09 REPAIR SYSTEM C – POLYMER-MODIFIED REPAIR MORTAR PLACEMENT

- A. Mix mortar in accordance with manufacturer's printed instructions.
- B. Bond Coat: Apply to prepared substrate concrete surface before application of mortar if applied during demonstration repair in accordance with repair mortar manufacturer's printed instructions. Do not apply more bond coat than can be covered with mortar before bond coat dries. Do not retemper bond coat.
- C. Place mortar by hand or low-pressure spray and trowel to specified surface finish, in accordance with requirements of repair material's printed instructions.
- D. Cure in accordance with Article Curing of this specification section, and in accordance with manufacturer's printed instructions.

### 3.10 FINISH

- A. Finish repair mortar to smooth even surface to match adjacent concrete surface or with a smooth trowel finish if there is no adjacent finished concrete.
- B. Tolerances:
  - 1. Wall must be plumb to within 1/4-inch in 10 feet.
  - 2. Depressions in wall surface must not exceed 1/4-inch when 10-foot straightedge is placed on high points in all directions.

### 3.11 CURING

- A. Prior to curing, apply water fog to repair mortar system in accordance with repair mortar system manufacturer's printed instructions.
- B. Cure in accordance with repair mortar manufacturer's printed instructions.
- C. Where permitted by repair mortar manufacturer's printed instructions, commence water curing after repair mortar system application and when curing will not cause erosion of mortar.

MWMC PRIMARY CLARIFIER AND  
FINAL TREATMENT CONCRETE REPAIR

- D. Continuously water cure repair mortar system for the length of time it takes the repair mortar to reach 4,000 pounds per square inch or the manufacturer's required cure period, whichever is greater.
- E. Do not cure using curing compound or membrane, unless method is part of repair mortar system manufacturer's printed instructions and approval is obtained from Engineer. Do not use curing compound on surfaces that will receive a future coating.
- F. Cure intermediate layers of repair mortar in accordance with repair mortar manufacturer's printed instructions.
- G. Where curing compound is permitted by repair mortar system manufacturer, apply curing compound in accordance with specification Section 03 39 00, Concrete Curing.

3.12 FIELD QUALITY CONTROL

- A. Sounding for Hollow Areas:
  - 1. Light hammer tap repaired areas listening for hollow sound to determine areas that have not properly bonded to substrate concrete.
  - 2. Mark hollow areas for removal and replacement.
- B. Testing laboratory retained by Owner will provide the following:
  - 1. Compression Strength Test:
    - a. Testing will follow a ASTM C109/C109M.
    - b. Cure test samples as specified.
    - c. A minimum of three production samples of mixed material will be obtained from each 500 square feet of mortar repair, and a minimum of three samples in total, whichever is greater, for testing at 7 days, and 28 days.
    - d. Record location where repair mortar is being applied at time production samples are obtained.
  - 2. Direct Tension Bond Test:
    - a. In situ Bond Testing: Perform tension bond test in accordance with ASTM C1583/C1583M.
    - b. Perform three tests for each 2,000 square feet of repair work but not less than three tests on each of the six long walls and one test on each of the end walls of the chlorine contact basins.
    - c. Record locations of Bond Tests on each type of applied repair mortar tested.

## MWMC PRIMARY CLARIFIER AND FINAL TREATMENT CONCRETE REPAIR

- d. Conduct test 10 days minimum after placement of mortar or as recommended by the repair manufacturer's representative.
  - e. Measure the expected mortar depth at the core locations prior to installing mortar.
  - f. Locate wall reinforcing prior to drilling core holes. Avoid cutting existing reinforcing.
  - g. Tests that have the failure in the concrete substrate pass. Tests that have the failure at the interface between the concrete substrate and the repair mortar or within the repair mortar fail.
- C. Retest mortar repairs that do not meet test requirements.
- D. Repair and fill holes using same repair mortar where core samples have been removed.

### 3.13 MORTAR REPAIR FAILED TEST

- A. Remove and replace unacceptable Work.
- B. Hollow Sounding Areas: Saw cut hollow sounding areas to a new square edge. Remove unsound mortar repair. Prepare substrate surface and reapply repair mortar as specified herein.
- C. Failed Compression Strength Test: Remove affected areas of repair mortar represented by failed compression strength test results. Prepare substrate surface and reapply repair mortar as specified herein.
- D. Failed Bond Tests: Remove affected areas of repair mortar represented by failed bond test results. Prepare substrate surface and reapply repair mortar as specified herein.
- E. Retest areas where repair mortar was removed and replaced, in accordance with test requirements specified herein.

### 3.14 MANUFACTURER'S SERVICES

- A. Provide repair mortar system manufacturer's representative at Site to review acceptability of surface preparation, mixing and installation assistance, training of repair mortar system applicators, inspection, and certification of proper installation.
- B. The representative must be onsite daily during the first 3 days of repair mortar application and at least weekly thereafter as required to confirm surface preparation and mortar application procedures.

MWMC PRIMARY CLARIFIER AND  
FINAL TREATMENT CONCRETE REPAIR

3.15 CLEANING

- A. Remove overshot shotcrete, Repair System A and low-pressure spray, Repair System B repair mortar and rebound materials as the Work proceeds. Remove waste materials, unsound material from concrete surfaces, and material chipped from structure and dispose offsite at an approved disposal site. Water used in preparation of repair areas, finishing, and curing may be disposed of onsite in coordination with Owner.

3.16 SUPPLEMENT

- A. The supplement listed below, following “End of Section,” is a part of this specification:
  - 1. Procedure for Disposal of Special, Hazardous, and Universal Waste.

**END OF SECTION**



Users of this document are responsible to ensure it is the most current version. Otherwise this document is invalid.

## CITY OF EUGENE – WASTEWATER DIVISION Procedure for Disposal of Special, Hazardous, and Universal Waste

<b>Subject:</b>	Hazardous Materials, Hazardous Waste, Special waste, and Universal Waste Management	<b>Document No:</b>	WW - 113
<b>Reviewed By:</b>	Tanya Haeri-McCarroll	<b>Date Prepared:</b>	2/16/01
<b>Approved By:</b>	Management Team	<b>Date Reviewed/ Revised/ Approved</b>	2/29/2024

### I. PURPOSE

The Wastewater Division manages hazardous materials, hazardous waste, universal waste, and special waste in a manner that will ensure the safety of employees and visitors, and protect the public and environment from hazardous materials releases. The Wastewater Division adheres to all applicable federal, state, and local laws, codes, statutes, and regulations that govern the safe handling and disposal of hazardous materials.

### II. SCOPE & APPLICABILITY

It is the responsibility of the Wastewater Division to identify and appropriately manage hazardous materials, hazardous waste, universal waste, and special waste. All employees must comply with this program.

### III. DEFINITIONS

- A. **EPA I.D.** This number identifies each handler (the transporter, generator, and treatment storage and disposal facility) on hazardous waste manifests and other paperwork. The identification number enables regulators to track the waste from origin to final disposal ("cradle to grave"). These numbers are site-specific and there must be only one number at a single address. If you have a business that generates waste at multiple addresses, each address needs a separate identification number.
- B. **Generator** is any person, by site, whose act, process produces hazardous waste, or whose act first causes a hazardous waste to become subject to regulation.
- C. **Hazardous Waste**, as defined by the Resource Conservation & Recovery Act (RCRA), is a chemical waste that meets one or more of the following criteria:
  - Flammable/Ignitable** - Substances that catch fire easily with a flashpoint of less than 140 degrees F (examples include flexible collodion and alcohol).
  - Corrosive** - Acids and caustic materials that can damage human tissue (skin, eyes, respiratory system). Corrosives have a pH of less than 2.0 or greater than 12.5 (examples include hydrochloric acid, sulfuric acid, concentrated glacial acetic acid, and sodium hydroxide).



Users of this document are responsible to ensure it is the most current version. Otherwise this document is invalid.

**Reactive** - These materials react violently when combined with other materials (examples include concentrated hydrogen peroxide).

**Toxic** - Substances that are poisonous to the body's organs (examples include solvents, ethylene oxide). They meet certain specified toxicity criteria that is included in the Environmental Protection Agency (EPA) list of hazardous or extremely hazardous material.

- D. **Resource Conservation and Recovery Act (RCRA)** is a Federal statute that regulates generators, transporters, and facilities that treat, store, or dispose of hazardous waste. All RCRA hazardous wastes are identified in Part 261 of title 40 Code of Federal Regulations and appendices.

#### IV. HAZARDOUS MATERIALS

- A. The Wastewater Division stores and uses hazardous materials for operation and maintenance purposes.
- B. The City of Eugene issues a Hazardous Materials Permit annually.
- C. The Wastewater Division reports amount of hazardous materials stored at its facilities to the State of Oregon Fire Marshall.
- D. Staff are required to store hazardous materials to prevent potential exposure or release to human health and the environment.
- E. All compressed gases must be secured. They must be labeled with its contents and whether they are full or empty. Compressed gases must be transported using a dolly intended for compressed gas.
- F. Ensure materials are labeled per the Hazard Communication Standard.
- G. Staff are required to use the hazardous materials for its intended use and follow instructions on the Label.

#### V. HAZARDOUS WASTE GENERATOR STATUS

- A. The Wastewater Division is categorized as a **Very Small Quantity Generator (VSQG)** (EPA ID # is not required). The facility produces 100 kilograms (220 pounds) or less per month for all hazardous waste generated onsite. The total amount of hazardous waste accumulated at any one time will not exceed 1,000 kilograms (2,200 pounds). Currently, acute hazardous waste is not produced at the Wastewater Division.
- B. A VSQG cannot store non-acute hazardous waste more than 6,000 kg. at any one time. If there is 1000 kg or more, it must be removed within 180 day from the date the accumulation exceeded the amount. The accumulation date begins the first day the waste begins accumulation. The waste must be transported for proper disposal.
- C. Hazardous waste may not be diluted or intentionally mixed with solid waste, dumped or spread on the ground, abandoned, burned, incinerated, evaporated, or buried on-site. Mixing hazardous waste with any other waste material may cause the entire mixture to be regulated as hazardous waste.
- D. The Wastewater Division is not permitted to transport or treat hazardous waste.

#### VI. WASTE GENERATED



Users of this document are responsible to ensure it is the most current version. Otherwise this document is invalid.

**A. Hazardous Waste**

1. Various paint products.
2. Aerosol cans.
3. Pesticides
4. Fertilizers
5. Lab waste (list)
6. Out-dated chemicals
7. Other

**B. Special Waste (hazardous waste determination required annually)**

1. Iron Sponge
2. Carbon
3. Alum
4. Grit
5. Struvite

**C. Universal Waste**

1. Batteries – alkaline, ni-cad, lithium
2. Lead-acid batteries
3. Mercury containing lamps (Fluorescent Light Bulbs)
4. Mercury containing equipment
5. Universal waste pesticides

**A hazardous waste determination must be conducted on waste that is unknown.**

**VII. CONTAINER MANAGEMENT AND LABELING**

**A. Container Management**

1. Universal waste batteries must be segregated by type. Lamps must be stored in such away as to avoid breaking them. Lead-acid batteries must be stored in secondary containment.
2. Empty Containers
  - a. Containers with small amounts of hazardous waste residues (<0.3% of the volume) are generally not considered to be regulated hazardous waste and can be disposed of as a solid waste with the exception of acutely hazardous waste. Empty containers of acutely hazardous waste are still required to be handled as a hazardous waste.
  - b. A container is considered RCRA “empty” when all wastes have been removed by using common industrial transfer practices, and not more than 0.3% of the volume remains.
  - c. Containers holding compressed gases are considered empty when the gas product contents have been used and the container is at atmospheric pressure.
  - d. Aerosol cans using a compressed gas propellant are considered empty when the container meets the empty condition for the product contents. For example, a spray can that is full of solvent-based paint or ether starting fluid, but that has no remaining propellant gas pressure, may still be considered a hazardous waste. Releasing a



Users of this document are responsible to ensure it is the most current version. Otherwise this document is invalid.

- compressed hazardous gas to the atmosphere or allowing container contents to evaporate to make the container empty is NOT allowed.
- e. If "empty" containers are mismanaged so that they generate a secondary waste (e.g., empty containers with hazardous residues are allowed to accumulate rainwater) the secondary waste stream will be subject to regulation if it is characteristically hazardous.
3. Containers must be compatible with the waste in them. For example, some corrosive liquids may be incompatible with metal containers by compromising the container's integrity and causing a leak. A composite drum or plastic drum must be used instead.
  4. Containers must be kept closed except when waste is actually being added. The RCRA definition of closed means "leak-proof and vapor-tight".
  5. Containers used to store hazardous waste must be in good condition. Containers must not be leaking, bulging, rusting, damaged, or dented.
  6. All hazardous waste must be placed inside the storage containers. If waste is spilled onto the top or sides of a container, it must be cleaned up immediately.
  7. Empty drums need to be triple rinses and stored upside down. When possible, recycle metal and plastic drums.
  8. Shelves used to hold waste containers must be in good condition.
  9. Incidental storage or use of flammable and combustible liquids (per OSHA 29 CFR 1910.106 (e)(2)(ii)(b)).
    - a. The quantity of liquid that may be located outside of an inside storage room or storage cabinet in a building or in any one fire area of a building cannot exceed:
      - i. 25 gallons of Class IA liquids in containers.
      - ii. 120 gallons of Class IB, IC, II, or III liquids in containers.
      - iii. 660 gallons of Class IB, IC, II, or III liquids in a single portable tank.
    - b. Design, construction, and capacity of storage cabinets (OSHA 29 CFR 1910.106 (d)(3)(i&ii)).
      - i. Maximum capacity: Not more than 60 gallons of Class I or Class II liquids, nor more than 120 gallons of Class III liquids may be stored in a storage cabinet.
      - ii. Fire resistance. Storage cabinets must be designed and constructed to limit the internal temperature to not more than 325°F when subjected to a 10-minute fire test using the standard time-temperature curve as set forth in Standard Methods of Fire Tests of Building Construction and Materials, NFPA 251-1969. All joints and seams must remain tight and the door must remain securely closed during the fire test. Cabinets must be labeled in conspicuous lettering, FLAMMABLE-KEEP FIRE AWAY.
      - iii. Metal cabinets constructed in the following manner must be deemed to be in compliance. The bottom, top, door, and sides of cabinet must be at least No. 18 gauge sheet iron and double walled with 1½-inch air space. Joints must be riveted, welded, or made tight by some equally effective means. The door must be provided with a three-point lock, and a door sill must be raised at least 2 inches above the bottom of the cabinet.

## B. Container Labels

1. Universal waste must be labeled: "Universal Waste [insert type, e.g. lithium batteries]."



Users of this document are responsible to ensure it is the most current version. Otherwise this document is invalid.

2. For accumulation of hazardous waste at the work area, the following labeling requirements apply:
  - a. Labels must be legible and any old or damaged labels must be removed.
  - b. The date that accumulation begins must be clearly marked and visible for inspection on every container.
  - c. The words, "Hazardous Waste" and content, must be clearly marked.
3. When a hazardous chemical or product is designated for disposal (it is no longer needed or it is outdated), the following labeling requirements apply:
  - a. All containers must be clearly labeled with the words, "Hazardous Waste". Labels must be legible and any old or damaged labels must be removed.
  - b. The containers must be labeled with the date the hazardous chemical or material was designated for disposal.
  - c. If the original label is not in place or legible, label with the contents.
  - d. Name and address,.

## VIII. ACCUMULATION

### A. Accumulation Area

Hazardous waste may be accumulated in designated satellite accumulation areas approved by the Safety Manager. Hazardous waste is often accumulated near the point of generation by workers in the immediate area. The RCRA regulation refers to this type of hazardous waste accumulation area as a satellite accumulation area.

1. A satellite accumulation area is a convenient way to control and store hazardous waste before it is moved to the facility's central accumulation area.
2. The satellite area must be near the area of generation and under the control of the employees who generate the waste.
3. There is no time limit on how long it takes to fill a container; however, there can only be one full container or an aggregate of small containers, limited to 55 gallons, in a satellite storage area at any one time.
4. The waste accumulation container must be at or near any point of generation and under the control of the operator.
5. If the waste being generated is considered to be acutely hazardous waste, the accumulation limit is one (1) quart.

Once a container in a satellite accumulation area is filled to capacity or the accumulation limit is reached; the accumulation start date must be filled in on the container label.

## IX. TRANSPORT

When shipping hazardous waste, a generator must:

- A. Only use treatment, storage, and disposal facilities (TSDF) that are registered or permitted by the regulatory authority (Environmental Protection Agency or Oregon DEQ).
- B. Complete Lane County's Hazardous Waste Collection Program form. Submit the form to Lane County and request an appointment for drop-off.

Ensure all containers are properly labeled, in secondary containment, and incompatible chemicals are segregated.



Users of this document are responsible to ensure it is the most current version. Otherwise this document is invalid.

## **X. SPECIAL WASTE**

A special waste permit is obtained from Lane County annually. As directed by Lane County, Wastewater will conduct hazardous waste determination and provide the documentation to Lane County. Once approved by Lane County, this waste is transported by staff to Lane County's landfill for disposal.

## **XI. DRAIN DISPOSAL**

- A. Some chemicals not classified as RCRA hazardous waste may be disposed down the drain to the sanitary sewer with proper approval. The Operations Manager decides what is acceptable to go down the drain.
- B. Under no circumstances is waste dumped down storm drains.

## **XII. HAZARDOUS WASTE MINIMIZATION**

The Wastewater Division makes efforts to minimize hazardous waste. The Director/Manager supervising the department that generates hazardous waste is responsible for minimizing hazardous waste generation. Each department must make an effort to reduce the amount of hazardous waste the department generates through the following:

- A. Substituting products that have non-hazardous or less hazardous equivalents, when possible;
- B. Recycling;
- C. Purchasing only amounts that are needed e.g. small quantities; and
- D. Redesigning the work process to reduce the amount of waste generated.

## **XIII. EMERGENCY PROCEDURES**

### **Also reference the Emergency Preparedness and Response Procedure (WW-14)**

- A. Contingency/emergency planning is the process of predetermining responses to a large release of hazardous waste. The Wastewater Division ensures operations minimize the possibility of a fire, explosion, or any unplanned release of hazardous waste or hazardous waste constituents to air, soil, or surface water that could threaten human health or the environment.
- B. The following equipment is required and is available at the hazardous waste central accumulation area:
  - 1. Internal communication or alarm system to provide immediate instruction to personnel;
  - 2. A telephone or cell phone capable of summoning emergency assistance from local police departments, fire departments, or state/local emergency response teams;
  - 3. Portable fire extinguishers, fire control equipment, spill containment equipment, and decontamination equipment; and
  - 4. Fire suppression system (e.g. water at adequate volume and pressure to supply water hose streams, foam producing equipment, automatic sprinklers, or water spray systems).
- C. All communications and alarm systems, fire protection equipment, spill control equipment and decontamination equipment, where required, is tested and maintained as necessary to ensure its proper operation in time of emergency.



Users of this document are responsible to ensure it is the most current version. Otherwise this document is invalid.

- D. Whenever hazardous waste is being handled, all personnel involved in the operation must either have immediate access to an internal alarm or emergency communication device, directly or through visual or voice contact with another employee.
- E. Aisle space is maintained to allow the unobstructed movement of personnel, fire protection equipment, spill control equipment and decontamination equipment to any area of operation in an emergency.

#### **XIV. RESPONSIBILITIES**

##### **A. Employees**

- 1. All employees should be familiar with the hazards of any chemical they work with, and ensure that it is non-hazardous before disposing of any substances in regular trash.
- 2. All employees are required to take Hazard Communication training annually.
- 3. All employees handling hazardous waste must ensure containers are properly labeled, stored, closed, and secured.
- 4. Employees should take precautions when transporting waste.

##### **B. Directors, Managers, and Supervisors**

- 1. Management is responsible for ensuring that hazardous wastes generated within their departments are stored, packaged, labeled, handled, and disposed of in accordance with applicable this policy and procedure and Federal and State regulations, and local codes.
- 2. Ensure employees are managing or handling hazardous waste properly.

##### **C. Facilities Maintenance Supervisor**

- 1. In coordination with the Safety Manager, manage special waste.
- 2. Monitor Paint Room waste for proper storage and disposal.
- 3. Work with Safety Manager to transport Hazardous Waste to Lane County for proper disposal.

##### **D. Safety Manager**

- 1. The Safety Manager will perform research as needed to determine whether a particular waste product or material is hazardous under any federal, state, or local regulations.
- 2. Coordinate hazardous waste determination when needed.
- 3. Coordinate drop-off or pick-up of hazardous waste.
- 4. Provide consultation on filling out hazardous waste labels.
- 5. Provide training for hazardous waste handlers as needed.
- 6. Participate in hazardous waste inspections by the local regulatory authority.
- 7. Manage the Specials Waste permit in coordination with Facilities Maintenance Supervisor.

#### **XV. Documentation**

Manage the following records:

- A. Special Waste Permit.
- B. Hazardous Materials Permit.
- C. Disposal records.



Users of this document are responsible to ensure it is the most current version. Otherwise this document is invalid.

- D. Hazard Surveillance reporting to State Fire Marshall (on-line).
- E. If the waste being disposed of is restricted from land disposal, the manifest files should contain a copy of the Land Disposal Restrictions (LDR) notice. Maintain these for three (3) years.
- F. Retain applicable employee training records. Recommend retaining training records for as long as the employee is employed at the facility.

## **XVI. REFERENCE:**

- A. 40 CFR 262 & 265, Standards Applicable to Generators of Hazardous Waste
- B. 49 CFR 172.704, Training Requirements
- C. 29 CFR 1910.1200, Hazard Communication
- D. 29 CFR 1910.38, Emergency Action Plans
- E. 29 CFR 1910.106 (e)(2)(ii)(b), Flammable and Combustible Liquids
- F. Emergency Preparedness and Response Procedure WW-14

**GENERAL SHEET NOTES**

- REMOVE EXISTING PIPE COATING, PREPARE SURFACE, AND RECOAT ALL CORRODED METALLIC PIPES WITHIN CLARIFIER WITH SYSTEM NO. 2 OR SYSTEM NO. 4 PER SPECIFICATION SECTION 09 90 00.
- CONTRACTOR TO SURVEY LAUNDER AFTER W2 RE-INSTALLATION TO CONFIRM NEW PIPING MATCHES DRAWINGS AND FUNCTIONS AS ORIGINALLY DESIGNED.
- WORK IN THE LAUNDERS MAY REQUIRE SHUTDOWN(S), PHASING, AND/OR COORDINATION WITH OWNER FOR TAKING CLARIFIERS OUT OF SERVICE. COORDINATE AS IDENTIFIED IN SPECIFICATION SECTION 01 31 13, PROJECT COORDINATION.

**SHEET KEYNOTES**

- REPLACE W2 PIPING WITH PVC PIPE. COAT UV EXPOSED PARTS OF PVC PIPES WITH SYSTEM NO. 25 PER SPECIFICATION SECTION 09 90 00.
- REMOVE AND REPLACE EXISTING W2 PIPE SUPPORTS. NEW PIPE SUPPORTS TO BE STAINLESS STEEL PER SPECIFICATION SECTION 40 05 15.
- ROUTE NEW PVC PIPING UP THRU ALUMINUM COVERS TO HOSE RISERS AT EACH HOSE RACK AROUND PRIMARY CLARIFIERS NO. 1 AND 3.
- HOSE RISER CONSTRUCTION TO BE SIMILAR TO PHOTO OF EXISTING HOSE RISER AT PRIMARY CLARIFIER NO. 1, SEE DETAIL 1 ON 031-DX-2001.
- INSTALL UNION JUST ABOVE THE PIPE JACK TO FACILITATE REMOVAL OR INSTALLATION OF THE ALUMINUM COVERS.
- PROVIDE AND INSTALL A V237, ALL BRONZE, ANGLE PATTERN HOSE VALVE WITH NPT THREADED ENDS AND THREADED RISING STEM AT EACH HOSE RISER. PROVIDE A CAST BRASS MALE NPT BY MALE NHT ADAPTER, STOCKHAM, FIGURE B-222T OR EQUAL. FIELD VERIFY VALVE SIZE AT EACH HOSE RISER PRIOR TO ORDERING VALVES.
- SEAL HOSE RISER TO ALUMINUM COVER WITH EPDM PIPE JACK, DEKITE OR EQUAL. SEE DETAIL 2 INCLUDED IN ADDENDA NO. 2.

NO.	DATE	BY	APVD
1	05/26	JM	R WALSH
ADDENDA NO. 2 PROCESS MECHANICAL REVISIONS		REVISION	CHK
		DR	D BRUNKOW
		DSGN	K KOTARSKA

**P80118**  
 MWC PRIMARY CLARIFIER AND FINAL TREATMENT STRUCTURAL REPAIR  
 METROPOLITAN WASTEWATER MANAGEMENT COMMISSION  
 EUGENE, OREGON

**Jacobs**  
 PRIMARY CLARIFIERS  
 PROCESS MECHANICAL COVERED PRIMARY CLARIFIERS DEMOLITION PLAN

VERIFY SCALE	DATE	03/24/2026
BAR IS ONE INCH ON ORIGINAL DRAWING.	PROJ	P80118
	DWG	031-DX-2001
	SHEET	11 of 17

100% DESIGN SUBMITTAL

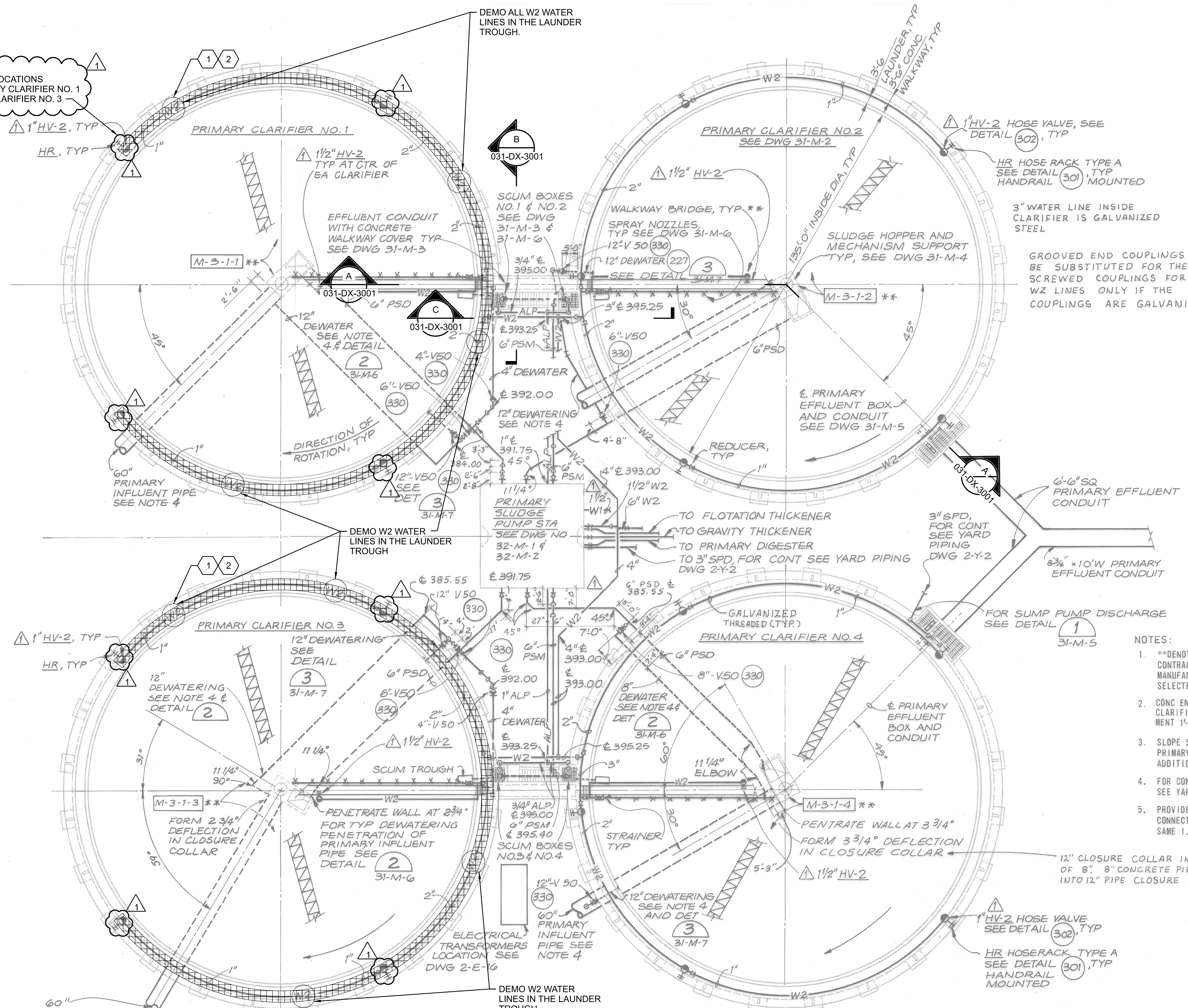

**NOTES:**

- \*\*DENOTES ITEMS FURNISHED BY OWNER AND INSTALLED BY CONTRACTOR. VERIFY DIMENSIONS REQUIRED WITH EQUIPMENT MANUFACTURER. REFER TO SHOP DRAWINGS FOR EQUIPMENT SELECTED.
- CONC ENCASE ALL PSD, PSM & DEWATERING PIPING UNDER CLARIFIER, EFFLUENT CONDUIT & SCUM BOXES & EXTEND ENCASEMENT 1'-0" MIN BEYOND STRUCTURE FOOTING. SEE DETAIL (227)
- SLOPE SCUM BOX ALP UNIFORMLY AND CONTINUOUSLY BETWEEN PRIMARY SLUDGE PUMP STATION AND TEE AT SCUM BOXES. FOR ADDITIONAL DETAILS, SEE DRAWING 31-M-6.
- FOR CONTINUATION OF PIPING AND FOR PIPING NOT SHOWN SEE YARD PIPING PLAN ON SHEET 2-Y-1 & 2-Y-2.
- PROVIDE STUBOUTS ON PRIMARY INFLUENT PIPE FOR CONNECTION TO DEWATERING PIPES. PROVIDE STUBOUT OF SAME I.D. AS CONNECTED DEWATERING PIPE, SEE DETAIL (2) 31-M-6



**1 DETAIL**  
 NTS  
 031-DX-2001

**COVERED PRIMARY CLARIFIERS - DEMOLITION PLAN**  
 1"=20'-0"

**GENERAL SHEET NOTES**

- REMOVE EXISTING PIPE COATING, PREPARE SURFACE, AND RECOAT ALL CORRODED METALLIC PIPES WITHIN CLARIFIER WITH SYSTEM NO. 2 OR SYSTEM NO. 4 PER SPECIFICATION SECTION 09 90 00.

**SHEET KEYNOTES**

- REPLACE W2 PIPING WITH PVC PIPE. COAT UV EXPOSED PARTS OF PVC PIPES WITH SYSTEM NO. 25 PER SPECIFICATION SECTION 09 90 00.
- STRUCTURAL WORK CAN BE PERFORMED WITH SCUM LINES AND ANY OTHER PIPING LEFT IN PLACE.
- BEGIN REPLACEMENT OF W2 PIPE DOWNSTREAM OF VALVE. FIELD VERIFY MOST CONVENIENT PLACE TO TIE IN TO EXISTING LINE. REPLACEMENT ONLY INCLUDES THE W2 PIPES IN THE LAUNDRY AND DOES NOT INCLUDE SPRAY BARS OR NOZZLES ON THE CLARIFIER BRIDGE.
- CORE TO REPLACE THE EXISTING 3" WATER SUPPLY THRU THE WALL INTO THE LAUNDRY AT PRIMARY CLARIFIERS NO. 1 AND 3. CORE AT SUFFICIENT DIAMETER TO REPLACE WATER SUPPLY PIPING WITH 3" PVC AND INSTALL LINK SEAL TO COMPLETE PENETRATION. FIELD VERIFY LOCATION OF EXISTING SUPPLY PIPE PRIOR TO BEGINNING CORE WORK.
- TIE NEW PENETRATION TO EXISTING WATER SUPPLY PIPING ON THE EXTERIOR OF THE CLARIFIER.

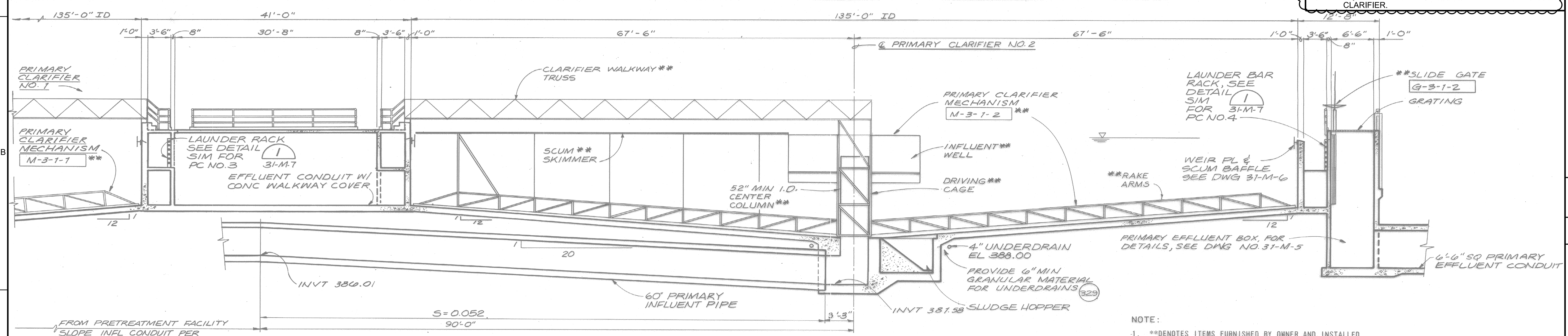

**A SECTION**  
1/8"=1'-0"  
031-DX-2001

- NOTE:**
- \*\*DENOTES ITEMS FURNISHED BY OWNER AND INSTALLED BY CONTRACTOR. VERIFY DIMENSIONS REQUIRED WITH EQUIPMENT MANUFACTURER. REFER TO SHOP DRAWINGS FOR EQUIPMENT SELECTED.
  - ◆ DENOTES ITEMS TO BE FURNISHED AND INSTALLED BY OTHERS.
  - SEE SHEET 39A FOR FLOOR STAND DETAILS

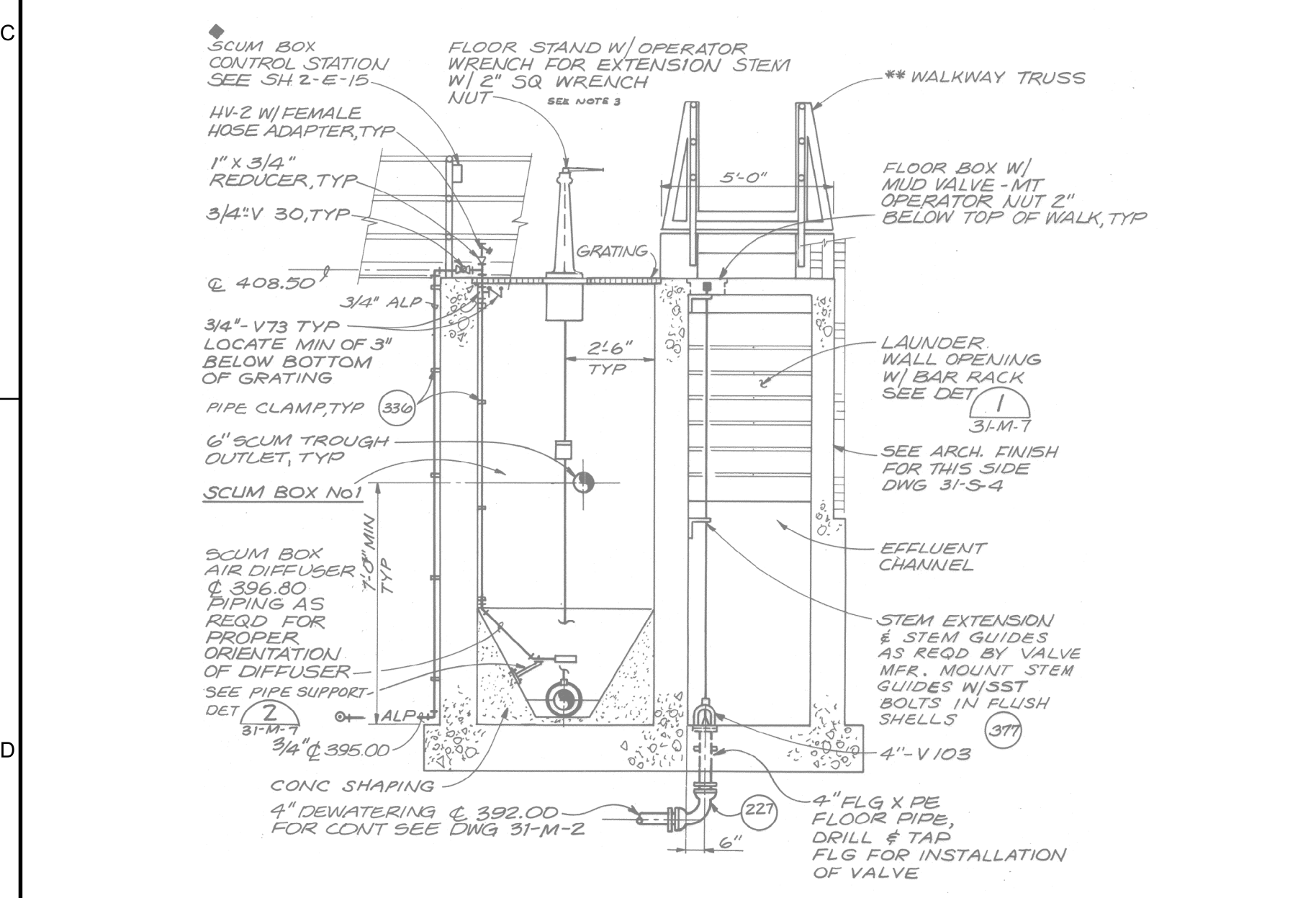

**B SECTION**  
1/4"=1'-0"  
031-DX-2001

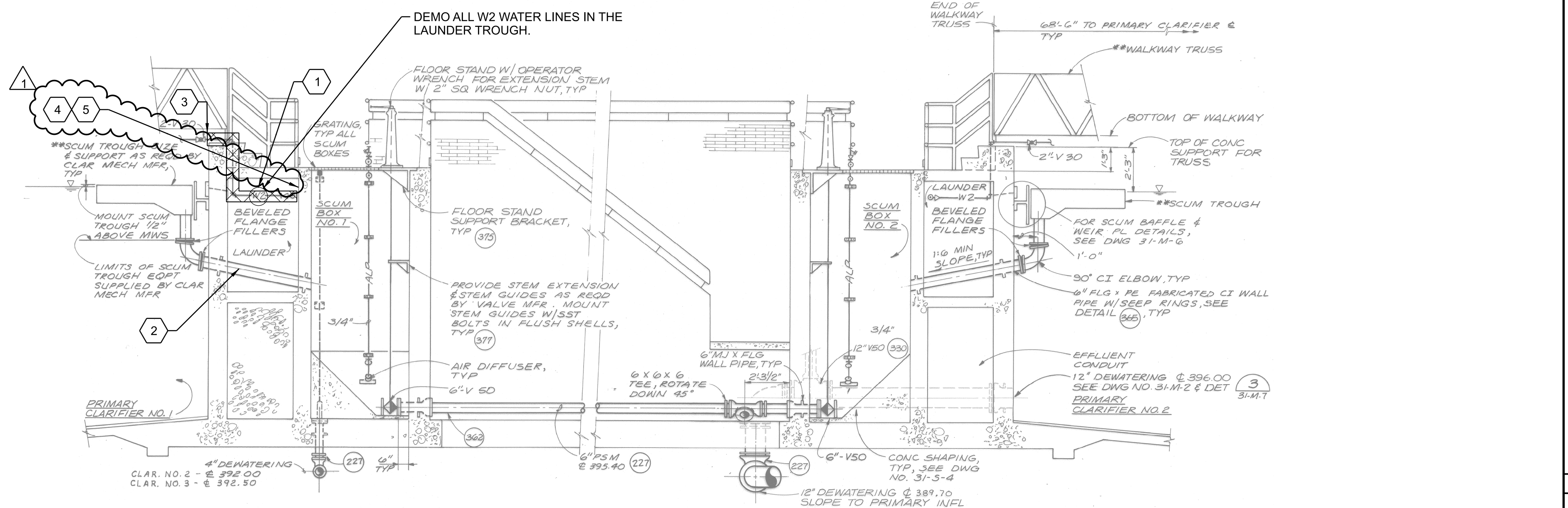

**C SECTION**  
1/4"=1'-0"  
031-DX-2001

NO.	DATE	BY	APVD
1	05/26	JM	DB

NO.	DATE	BY	APVD
1	05/26	JM	DB

NO.	DATE	BY	APVD
1	05/26	JM	DB

NO.	DATE	BY	APVD
1	05/26	JM	DB

100% DESIGN SUBMITTAL

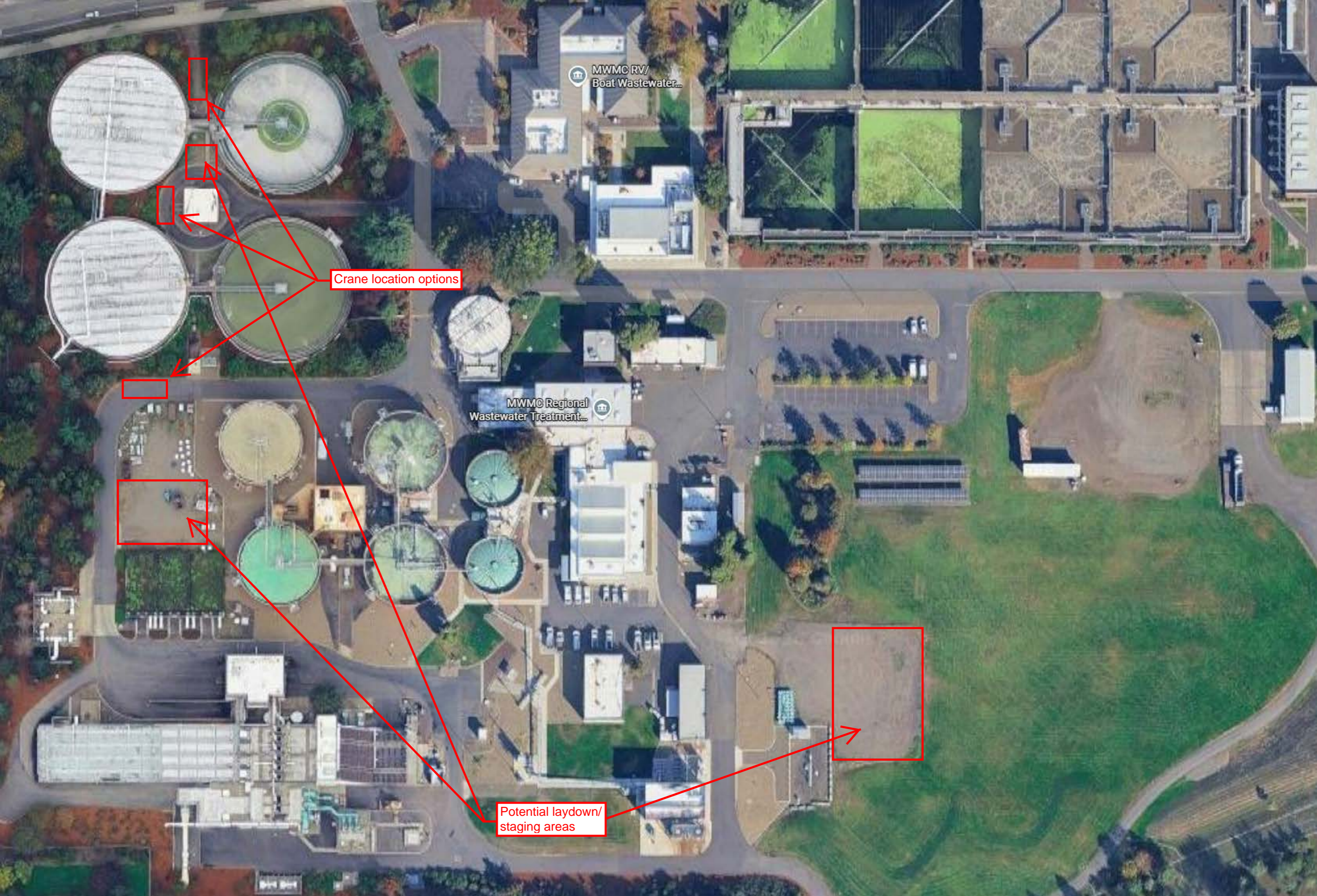

MWMC RV/  
Boat Wastewater...

Crane location options

MWMC Regional  
Wastewater Treatment...

Potential laydown/  
staging areas

River Ave

River Ave

River Ave

River Ave

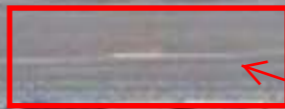

Crane location options



888

A laydown/staging area near the worksite will be provided. Exact location TBD